



# CHLORINE 3017M

DPD CHLORINE ANALYZER

Copyright

© 2024 Xylem Analytics Germany GmbH  
Printed in Germany..

## Contents

<b>1</b>	<b>Specifications .....</b>	<b>6</b>
<b>2</b>	<b>Safety instructions .....</b>	<b>8</b>
2.1	Safety Information .....	8
2.1.1	Safety information in the operating manual .....	8
2.1.2	Safety signs on the product .....	8
2.2	Safe operation .....	9
2.2.1	Authorized use .....	9
2.2.2	Requirements for safe operation.....	9
2.2.3	Unauthorized use .....	9
<b>3</b>	<b>General Information.....</b>	<b>10</b>
3.1	Instrument Description.....	10
3.2	Method of Analysis .....	11
3.3	Theory of Operation.....	12
3.4	Disposal.....	12
<b>4</b>	<b>Installation.....</b>	<b>12</b>
4.1	Unpack the analyzer.....	13
4.2	Environmental Considerations.....	13
4.3	Analyzer Mounting.....	13
4.4	Plumbing Connections.....	17
4.5	Sample Line.....	18
4.6	Sample Inlet Device.....	18
4.7	Optional In-Line Filter .....	21
4.8	Optional Sample Inlet Devices and Systems.....	21
4.9	Electrical Connections.....	21
4.9.1	Power Connections.....	22
4.9.2	Wiring the Analyzer.....	23
4.9.3	RS 485.....	25
4.9.4	Analog Output (4-20 mA) .....	25
4.9.5	Alarm (Relay) Connections .....	26
4.9.6	Reagent Preparation.....	26
4.10	Pump Tubes .....	28
4.10.1	Sample Pump Tube .....	28
4.10.2	Reagent Pump Tubes .....	29
<b>5</b>	<b>Analyzer Startup .....</b>	<b>30</b>
5.1	Supply the Sample .....	30
5.2	Supply Power to the Analyzer .....	31
5.3	LANGUAGE SELECTION .....	31
5.4	POWERUP MODE .....	32
<b>6</b>	<b>Analyzer Operation.....</b>	<b>33</b>
6.1	User Interface.....	33

6.2	Display.....	34
6.3	Touchpad .....	34
6.4	Description of Firmware Structure and Operation .....	37
6.5	Unlocking/Locking the Analyzer .....	46
6.6	Method Settings .....	46
6.7	Setting the 4-20 mA Output.....	47
6.8	Setting the Alarm/Timed Event Relays.....	47
6.8.1	Setting the Alarm Relays with the Keypad.....	47
6.8.2	Setting the Alarm Relays through MODBUS .....	49
6.9	Calibration .....	49
6.9.1	Calibration with a Known Standard.....	50
6.9.2	Calibration by Comparison.....	50
<b>7</b>	<b>Default Configuration and Method Settings.....</b>	<b>51</b>
7.1	Method Settings .....	52
7.1.1	Times .....	52
7.1.2	Pumps.....	52
7.1.3	LED's .....	53
7.2	Setup .....	53
7.2.1	Communications .....	53
7.2.2	4-20 mA Setup.....	53
7.3	Status .....	54
7.4	Linearization .....	54
7.5	Maintenance.....	54
<b>8</b>	<b>Maintenance.....</b>	<b>55</b>
8.1	Regularly Scheduled Maintenance.....	55
8.1.1	Reagent Replacement .....	55
8.1.2	Pump and Reagent Tube Replacement.....	55
8.2	Unscheduled Maintenance.....	60
8.2.1	Fuse Replacement.....	60
8.2.2	Flowcell Cleaning.....	60
8.2.3	Linearization.....	61
8.2.4	Field Linearization Procedure .....	62
<b>9</b>	<b>Troubleshooting .....</b>	<b>66</b>
9.1	Troubleshooting Guide .....	66
9.2	Using the Manual Controls and STATUS Screen for Troubleshooting.....	67
9.2.1	No Sample or Reagent Flow.....	67
9.3	Using Tier 3 Selections Under STATUS for Troubleshooting.....	68
9.3.1	Main STATUS screen .....	69
9.3.2	Liquid Level Sensor and Error Levels .....	72
9.3.3	Firmware and PCA Revision Levels .....	74
<b>10</b>	<b>Parts and Accessories .....</b>	<b>75</b>
<b>11</b>	<b>MODBUS.....</b>	<b>81</b>
11.1	0xxxx's Coils(Read/Write) .....	81

11.2 1xxx's Status Inputs(Read Only) .....	81
11.3 3xxx's Input Registers(Read Only) .....	82
11.4 4xxx's Input Registers(Read/Write) .....	84
11.5 Instrument Error Summary .....	87
11.6 Instrument Level 4 Errors .....	88
11.7 Instrument Level 3 Errors .....	89
11.8 Instrument Level 2 Errors .....	91
11.9 Instrument Level 1 Errors .....	92

# 1 Specifications

<b>General</b>	
Display	4 x 20 LDC backlit LCD
Language Support	English, Spanish, German, Italian, French
Enclosure	IP 66 (with latched door, clear)
Instrument Dimensions	42.67 cm x 37.6 cm x 18.8 cm (16.8 x 14.8 x 7.8 inches)
Mounting	Wall mount
Instrument Shipping Weight	8 kg (<18 lbs)
Warranty	WTW warrants its product to the original purchaser against any defects in material or workmanship for a period of two years from the date of shipment.
Certification	CE, Listed to UL and CSA Safety Standards by ETL
Sample Requirements	
Sample flow rate to Sample Inlet Device	50 to 1,000 mL/min when using WTW Sample Inlet Device, order number 860188.
Inlet Pressure	0.07 to 1.40 bar (1 to 20 psi) at WTW Sample Inlet Device, order number 860188
Sample Temperature Range	5 to 55 °C (41 to 131 °F)
Inlet Fitting at Sample Inlet Device	1.27 cm (½-inch) barb fitting with flexible hose (standard). Can be adapted to most tubing sizes with the appropriate fittings.
Outlet Fitting at Sample Inlet Device	1.27 cm (½-inch) barb fitting with flexible hose (standard). Can be adapted to most tubing sizes with the appropriate fittings.
Inlet Fitting at Instrument	3.18 mm (1/8-inch) OD Teflon tubing with quick-connect fitting
Drain Fitting at Instrument	1.27 cm (½-inch) barb fitting with flexible hose
Sample Conditioning	None required in most cases.
Reagent/Standard Requirements	
Maximum Reagent Usage	500 mL per month for Indicator and Buffer
Reagent Containers	High-density polyethylene; (2) 500 ml bottles
Reagent Containment	Reagent bottles are contained inside the analyzer enclosure.

<b>Electrical</b>	
Power	115-230 VAC, 50-60 Hz, 70 VA
Connection	3-wire Bulkhead cord seal strain relief to push-in DIN rail terminal blocks
Safety Class	I
Relays	(2) 30 VDC, 6A; NO/NC; SPDT, Potential Free
Alarm Outputs	Potential-free relays rated at 30VDC, 6A. Can function as sample high/low set point alarms or as system warning/alarm indicator.
Analog Outputs	4-20 mA configurable with alarm switch
Digital Outputs	RS-485 Modbus RTU protocol or ASCII standard
<b>Optical</b>	
Light Source	Class 1 LED; Wavelength selectable from 475 nm to 625 nm; Operates at wavelength centered at 525 nm. 50,000 hours estimated minimum lifetime
<b>Performance</b>	
Operating Range	0-5 mg/L Free or Total Chlorine
Cycle Time	Programmable; 2.5 to 60 minutes
Accuracy	±5% or ±0.03 mg/L whichever is greater
Precision	±5% or ±0.01 mg/L whichever is greater
Limit of Detection	0.03 mg/L
Limit of Quantitation	0.09 mg/L
Calibration	Default calibration curve; adjustable if necessary
Power Switch	External power switch recommended
<b>Environmental</b>	
Storage Temperature Range	5 – 70 °C (41 – 158 °F)
Operating Temperature Range	5 – 55 °C (41 – 131 °F)
Relative Humidity	90% at 40°C (non-condensing)

## 2 Safety instructions

### 2.1 Safety Information

#### 2.1.1 Safety information in the operating manual

This operating manual provides important information on the safe operation of the product. Read this operating manual thoroughly and make yourself familiar with the product before putting it into operation or working with it. The operating manual must be kept in the vicinity of the product so you can always find the information you need.

Important safety instructions are highlighted in this operating manual. They are indicated by the warning symbol (triangle) in the left column. The signal word (e.g. "CAUTION") indicates the level of danger:

**DANGER**

*indicates a potentially or imminently hazardous situation which, if not avoided, will result in serious injury or death.*

**WARNING**

indicates a condition or possible situation that could result in physical injury to the operator.

**CAUTION**

indicates a condition or possible situation that could damage or destroy the product or the operator's work.

**NOTICE**

indicates a situation where goods might be damaged if the actions mentioned are not taken.

#### 2.1.2 Safety signs on the product

Please read all labels and tags attached to the instrument. Personal injury or damage to the instrument could occur if not observed.



This is the safety alert symbol. Obey all safety messages that follow this symbol to avoid potential injury. If on the instrument, refer to the instruction manual for operation or safety information.

## 2.2 Safe operation

### 2.2.1 Authorized use

The authorized use of the 3017M Chlorine Analyzer is its use for chlorine measurement. Only the operation and running of the 3017M according to the instructions and technical specifications given in this operating manual is authorized (see section 1). Any other use is considered unauthorized.

With unauthorized use, the protection type supported by the instrument can be adversely affected.

### 2.2.2 Requirements for safe operation

Note the following points for safe operation:

- The product may only be operated according to the authorized use specified above.
- The product may only be operated under the environmental conditions mentioned in this operating manual.
- The product may only be supplied with power by the energy sources mentioned in this operating manual.
- The product may only be opened if this is explicitly described in this operating manual (example: connecting electrical lines to the terminal strip).

### 2.2.3 Unauthorized use

The product must not be put into operation if:

- it is visibly damaged (e.g. after being transported)
- it was stored under adverse conditions for a lengthy period of time (storing conditions, see section 1).

## 3 General Information

### 3.1 Instrument Description

**DANGER**

***Chemical or biological hazards: If this instrument is used to monitor a treatment process and/or chemical feed system for which there are regulatory limits and monitoring requirements related to public health, public safety, food or beverage manufacture or processing, it is the responsibility of the user of this instrument to know and abide by any applicable regulation and to have sufficient and appropriate mechanism in place for compliance with applicable regulations in the event of malfunction of the instrument.***

The Model 3017M Chlorine Analyzer is a microprocessor-controlled process analyzer. It is designed to continuously monitor an aqueous sample for chlorine content. Either free or total chlorine, in the range of 0 – 5 mg/L can be monitored. The choice of range can be selected by the user. Indicator and buffer solutions are used for the determination of chlorine content. Specific buffer solutions are used for free or total chlorine.

**CAUTION**

**Fire hazard: This analyzer is intended to be used for aqueous samples only.**

The Model 3017M Chlorine Analyzer enclosure is rated for IP 66 per IEC 529. The enclosure is dust tight and drip resistant and is designed for outdoor use. However, a three-sided covering that prevents direct exposure to sunlight, dripping water, rain, sleet, or snow should be used.

The Model 3017M Chlorine Analyzer is an on-line photometric analyzer that uses N,N-diethyl-p-phenylene diamine (DPD) indicator and a buffer to determine chlorine content. The system has two peristaltic pumps that deliver sample and reagents to a Flowcell. The sample pump continually delivers sample to the Flowcell. The reagent pump is activated at a predetermined time to deliver buffer and DPD reagent to the sample stream.

The Flowcell consists of a sample inlet, reagent inlets, a static mixer and sample drain. Either a green, blue, or red LED can be selected to provide the appropriate wavelength of light. Light is transmitted through fiber optic cables through the Flowcell and back to a dual-channel detector. One channel is used for the analysis of the colored complex while the other channel is used as a reference to monitor the LED source, and thereby, maintain stability of the system.

The reagents are dispensed from two replaceable bottles. One bottle has a buffer to control the pH; the second bottle has the DPD reagent that produces a purple color when

chlorine is present in the sample. The degree of color change is proportional to the amount of chlorine in the sample water. Chlorine concentration is displayed on the front panel by three-digit LCD readout in mg/L chlorine.

The system accepts commands and sends data over RS-485 using Modbus RTU/ASCII protocols, or through the touchpad, if the instrument is not operated under Modbus control. A 4-20 mA output is available for connection to an external datalogger, Programmable Logic Controller (PLC) or Distributive Control System (DCS). Concentration minimum and maximum values in mg/L chlorine are set by the operator at the analyzer touchpad.

Programmable alarm circuits provide relay closures, both normally open and normally closed, for two selectable chlorine level set points. Set points can be programmed by the operator anywhere in the overall range. System warning and system alarm features provide automatic, self-testing diagnostics that detect a number of possible malfunctions, and provide alarm relay closures indicating a need for operator intervention.

Indicator and buffer reagent containers (500 ml each) are placed in the instrument enclosure. Reagents are replenished once a month when operating in the 0 – 5 mg/L chlorine range. A clear front cover allows for viewing of reagent bottles, and other critical components without the need for opening the analyzer enclosure.

### **3.2 Method of Analysis**

Free available chlorine (hypochlorous acid and hypochlorite ions) oxidizes the DPD indicator reagent at a pH between 6.3 and 6.6 to form a purple-colored compound (Würster dye). The intensity of the resulting color is proportional to the concentration of chlorine in the sample. A buffer solution specifically for free chlorine maintains the proper pH.

Total available chlorine (free chlorine and combined chloramines) is determined by adding potassium iodide to the reaction. Chloramines in the sample oxidize iodide to iodine, which, along with any free available chlorine, oxidizes DPD indicator to form the purple color at a pH of 6.5 – 8.5. A different buffer solution containing potassium iodide maintains the reaction pH. After the chemical reaction is complete, the optical absorbance at the selected wavelength is compared to the absorbance measured through the flowcell before the reagents are added. Chlorine concentration is calculated from the difference in absorbance.

### 3.3 Theory of Operation

The sample continuously flows through the flowcell. Prior to the addition of reagents, the blank absorbance is measured. Measurement of the sample blank allows for compensation for any turbidity or natural color in the sample and provides an automatic zero reference point. Reagents are added after the measurement of the blank sample and develop the purple color if chlorine is present in the sample. Absorbance is measured and compared to the blank reference value.

Peristaltic pumps control the flow of sample and reagents. The sample flows continuously and the reagent pump delivers a metered amount of buffer and indicator in a 2.5-minute cycle. The cycle operates as follows:

1. The sample is continuously flowing through the flowcell.
2. At a preset time, the absorbance of the blank sample is measured.
3. After the blank absorbance is measured, the indicator and buffer reagents are injected into the flowing stream of sample.
4. The sample and reagents are allowed to thoroughly mix for the full development of the purple color. The measurement of the treated sample is taken to determine the chlorine content.
5. The sample pump increases the flow rate to thoroughly evacuate the flow cell in preparation for the start of the next cycle.

### 3.4 Disposal

At the end of its operational lifetime, the meter must be returned to the disposal or return system statutory in your country. If you have any questions, please contact your supplier.

## 4 Installation



#### **DANGER**

***Electrocution and fire hazard. Only qualified personnel should conduct the tasks described in this section of manual.***



#### **WARNING**

**Electrocution hazard. Install a 10 A circuit breaker for mains power. Identify the circuit breaker with a label, as a local disconnect for this equipment.**

## 4.1 Unpack the analyzer

Remove the analyzer from the box and inspect it for damage. Verify that all of the parts are contained in the shipment. If any items are missing or damaged, contact Technical Support, or the local representative.

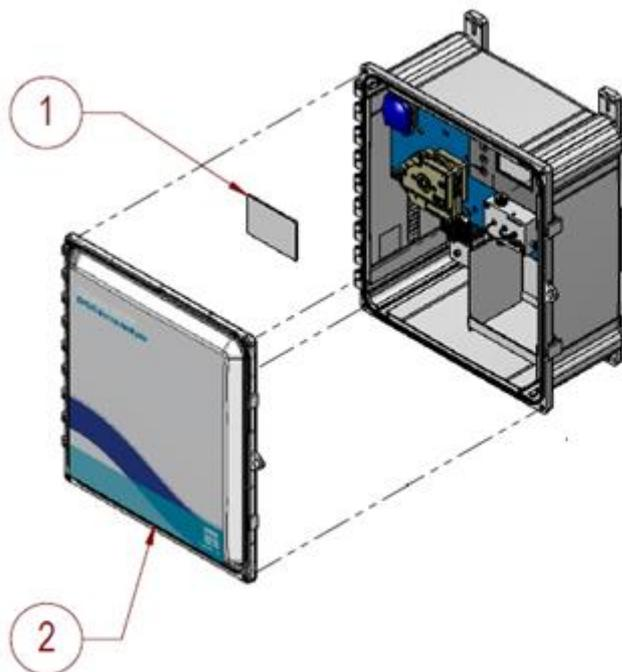

Figure 4.1 Chlorine 3017M DPD chlorine analyzer

- 1) 3017M Manual
- 2) Enclosure-3017M Cover

## 4.2 Environmental Considerations

The analyzer enclosure is designed for indoor or outdoor installation with an ambient temperature range of 5 – 55 °C (18 – 131 °F). The enclosure environmental rating is IP 66 with the door closed and latched. For outdoor installation, the analyzer should be covered by a three-sided cover to protect it from direct sunlight, dripping water, rain, sleet or snow.

## 4.3 Analyzer Mounting

The enclosure is designed for wall mounting. Refer to Figure 4.2, Figure 4.3, Figure 4.4 and Figure 4.5 for critical dimensions and other installation information.

The 3017M has four mounting tabs that must be installed on the enclosure refer to Figure 4.3. These mounting tabs can be found in a package of mounting hardware that is included with the enclosure. Connect the mounting tabs to the enclosure using the four (4) #10-32 x 3/8-inch Phillips Drive flat head machine screws found in the mounting hardware kit.

Use ¼-inch screws, or bolts, depending on mounting location/surface. The analyzer should be mounted at a height at which it can be safely operated. Mount the analyzer as close as practical to the sampling point to ensure complete purging of the sample line during each cycle. Leave adequate clearance at the sides and bottom of the analyzer enclosure for wiring and plumbing connections.

The most common installation approach is the use of Unistrut® frame. Unistrut frame with 6.35mm (¼-inch) spring nuts would be used for mounting the 3017M. The mounting tabs on the 3017M are designed for 6.35 mm (¼-inch) bolts.



The sample pump in the analyzer pulls sample into the flow cell. The maximum distance between the analyzer and the sample point should not exceed 1 m (3.28 ft).

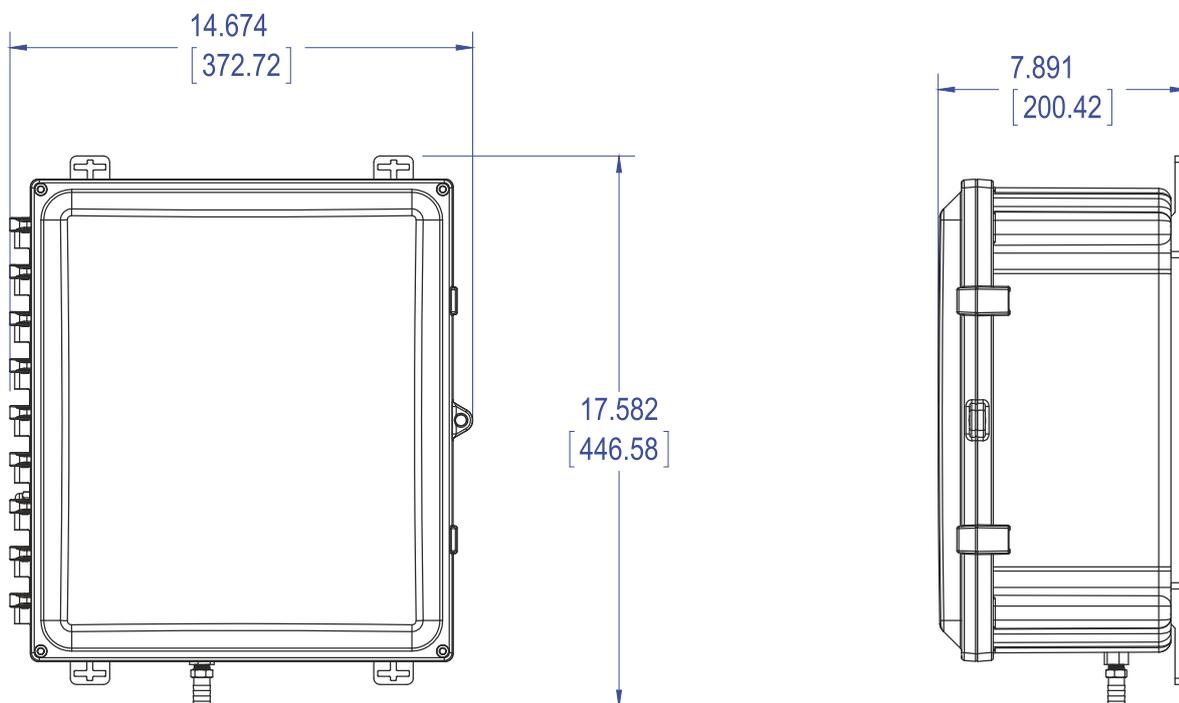

Figure 4.2 Model 3017M Overall Dimensions shown in inches (top number) and millimeters

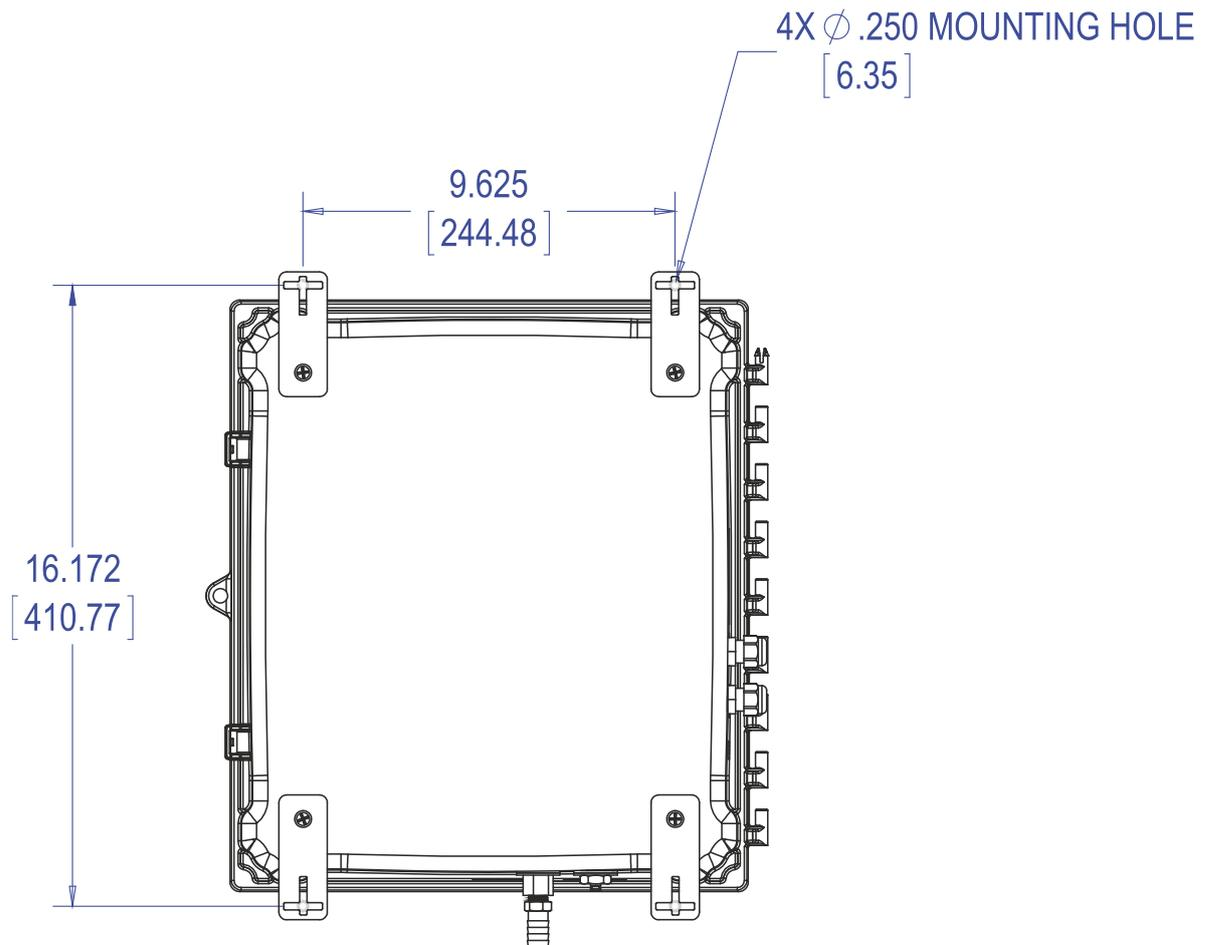

Figure 4.3 Model 3017M Mounting Dimensions showing the mounting tabs connected to the enclosure. Dimensions are shown in inches (top number) and millimeters.

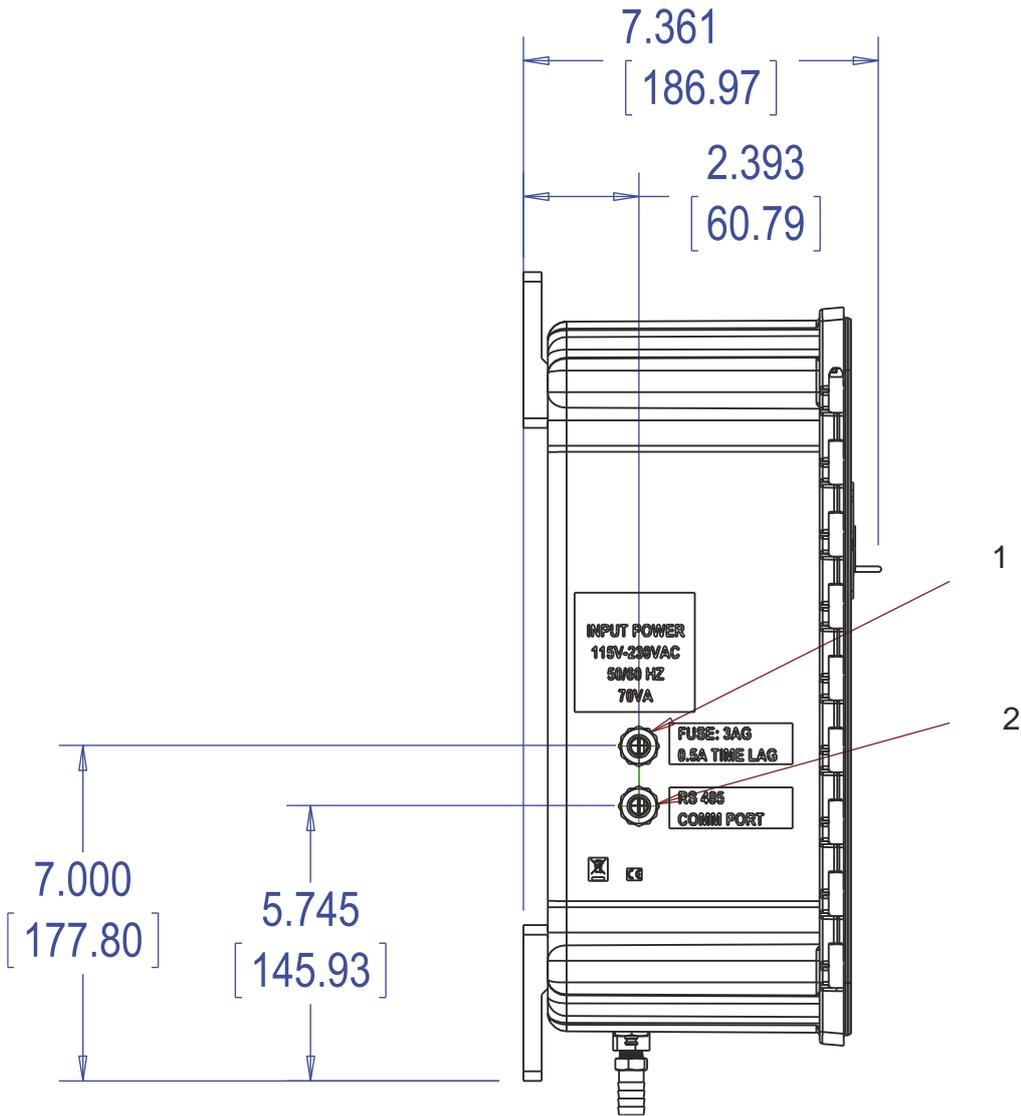

Figure 4.4 Model 3017M Electrical Connections. Dimensions are shown in inches (top number) and millimeters

- 1) Power Connection
- 2) RS 485 and 4-20 mA Connections

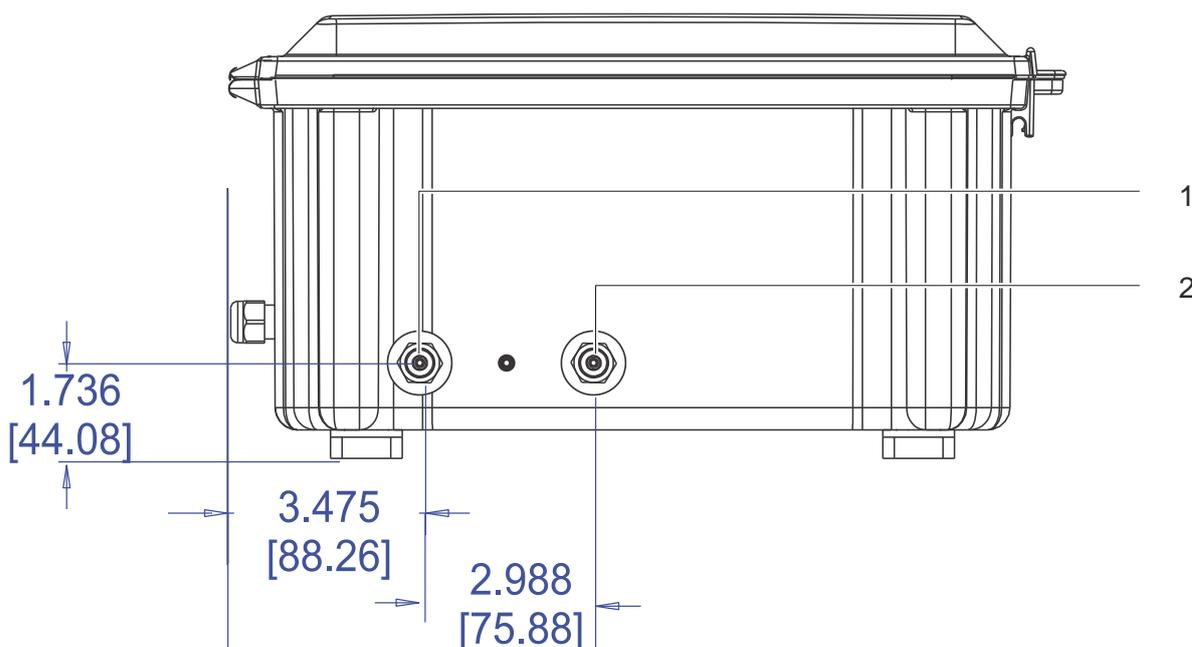

Figure 4.5 Model 3017M Plumbing Connections

- 1) Sample Inlet: Quick connect fitting for 3.175 mm (1/8 in) OD tubing
- 2) Waste: Barb fitting for 12.7 mm (1/2-inch) ID flexible tubing

## 4.4 Plumbing Connections



The waste line contains analysis waste, which include both sample and chemical reagents. The chemicals used for the analysis are of very low concentrations. Adhere to local codes for the proper disposal of this waste.

Sample inlet and waste connections are made on the bottom of the analyzer. The sample inlet is a quick connect fitting for a 3.175-mm (1/8-inch) OD tubing. The waste line is a barb fitting for 12.7-mm (1/2-inch) ID flexible tubing. See Figure 4.5. Connect the 3.175 mm (1/8-inch) OD Teflon® by pushing it into the fitting. A stop will be felt when the tubing is properly seated in the fitting. Connect the waste line by pushing, and gently twisting, the tubing over the barb on the fitting. Insure that the tubing completely covers the barb.



No pressure, positive or negative, should be applied to the waste line.  
Never plug the waste line..



**CAUTION**  
**Fire hazard. This analyzer is intended for water samples only.**

## 4.5 Sample Line

The selection of a representative sample is important for optimal performance of the analyzer and analytical results. The sample must be representative of the condition of the entire process. Erratic reading will be realized if the sample is drawn from a location that is too close to the point of chemical injection, if mixing is incomplete, or if the chemical reaction is incomplete.

Install sample line taps into the side or center of larger process pipes to minimize the chance of ingestion of sediment or air bubbles. A tap projecting into the center of a pipe is an ideal configuration. Opaque tubing is recommended if the tubing is exposed to sunlight in order to prevent algae growth.

## 4.6 Sample Inlet Device

The Sample Inlet Device, order number 860188, is shown in Figure 4.6. It is a simple, easy-to-use device that serves as the interface between the sample tap and the Model 3017M. It consists of inlet and outlet ports, a 60-micron filter for filtration of fine particles, if necessary, and a 1.40 bar (20 psi) pressure relief valve. The Sample Inlet Device is rated for line pressure in the range of 0.07 – 1.40 bar (1 – 20 psi). It may be necessary to install an in-line pressure regulator, or shut-off valve upstream of the Sample Inlet Device.

These instructions cover the plumbing connections for the Sample Inlet Device, order number 860188. See Figure 3.5. Other sampling schemes can be used with the 3017M. The critical point is that the sample inlet line from the 3017M is always immersed in sample that is representative of the process that is being monitored.

The instrument is designed to require very little head pressure to operate. If the Sample Inlet Device is being used the pressure range is 0.07 bar (1 psi) to 1.40 bar (20 psi). The maximum allowable fluid temperature is 50°C (122°F).

Opaque tubing is recommended if the tubing is exposed to sunlight in order to prevent algae growth. Note that the sample inlet and outlet connectors are compatible with ¼-inch (6.35-mm) O.D. flexible tubing. The outlet port of the Sample Inlet Device has a pressure relief valve that will open if the sample pressure through the device exceeds 1.4 bar (20 psi).

The 1/8-inch (3.175-mm) sample inlet line from the analyzer to the Sample Inlet Device will be connected to sample inlet side of the Sample Inlet Device through a bored-through, Swagelok® fitting with a Teflon® ferrule.

The analyzer has a separate drain for the flow from the sample and reagent pumps onboard the analyzer. The drain tubing is ½-inch (12.7-mm) flexible tubing.



The analyzer drain must be open to the atmosphere. No pressure, positive or negative, must be applied to the drain tube.



The waste from the drain connection of the instrument contains reagents diluted with large quantities of water. Route the drain line from the analyzer to the appropriate point in accordance with local codes or regulations.

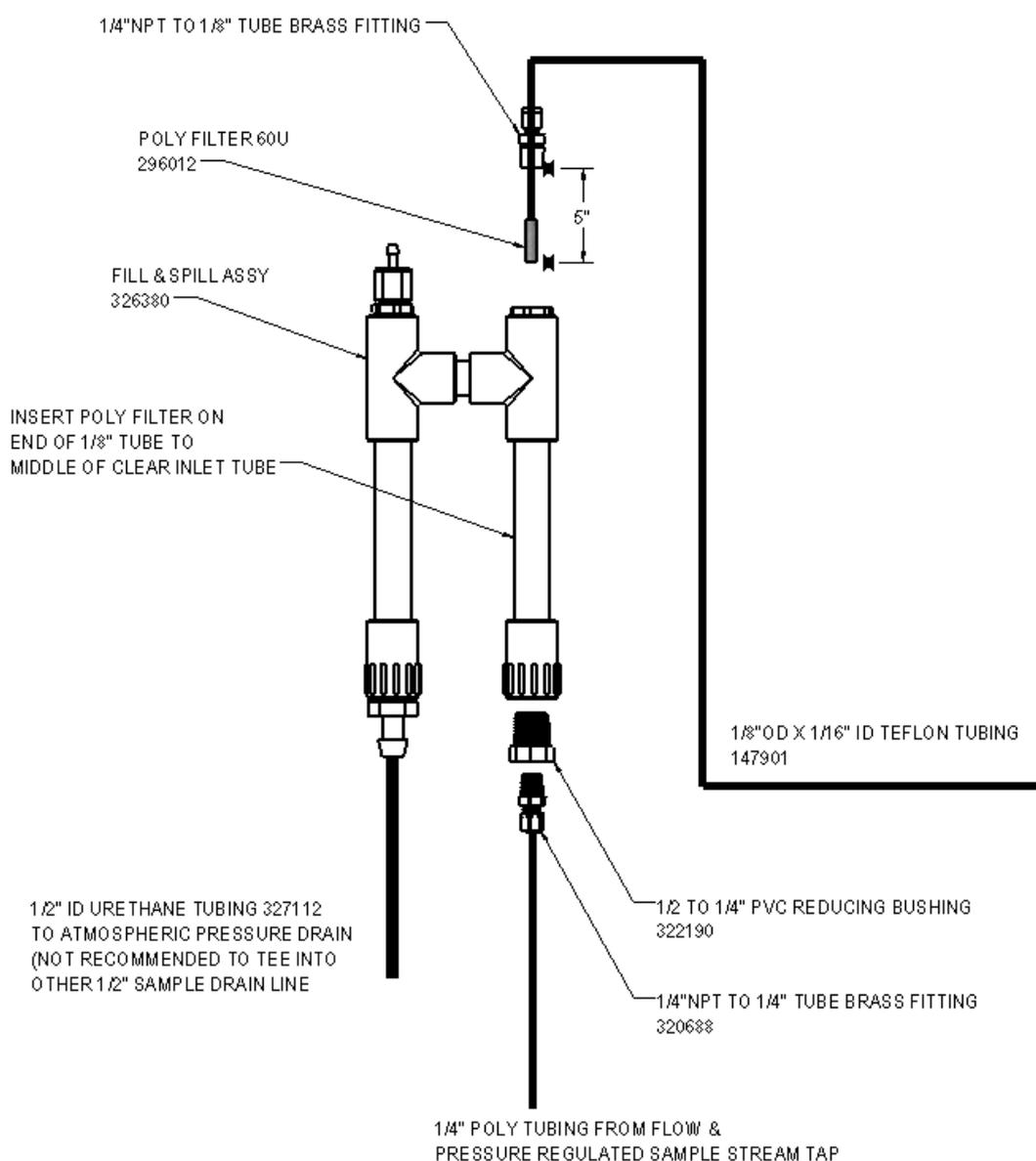

Figure 4.6 Sample Inlet Device (Order number, 860188)

The ideal location for the Sample Inlet Device is below the Model 3017M and as close as practical to the 3.175 mm (1/8-inch) quick connect fitting at the bottom of the analyzer. The

installation location of the Sample Inlet Device should not exceed 1 m (3.28 ft) from the analyzer. See Figure 4.7.

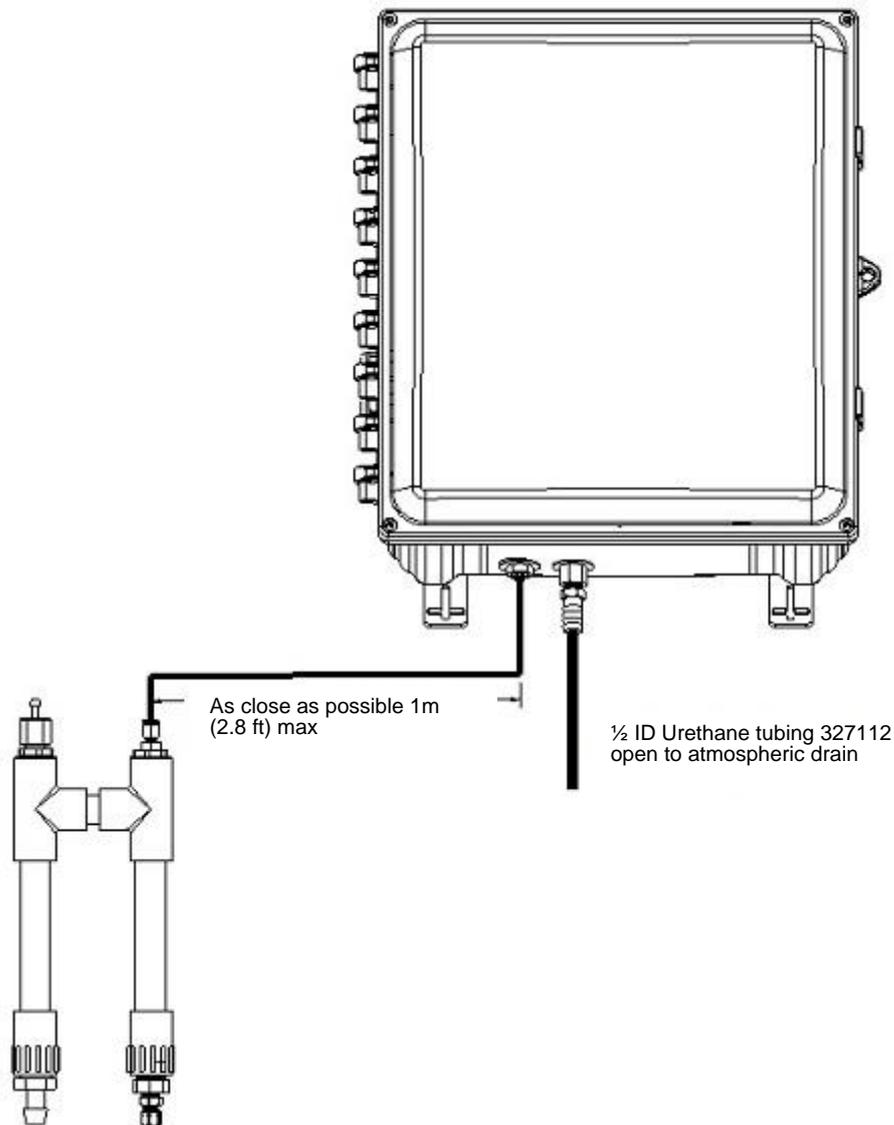

Figure 4.7 Recommended position of Sample Inlet Device with Model 3017M

The Sample Inlet Device is supplied with quick connect fittings for 6.35-mm (1/4-inch) OD tubing. Other fittings may be substituted depending on the application, but these are not supplied with the device.

Secure the Sample Inlet Device to the wall, panel, or other structure. Push 6.35-mm (the 1/4-inch) OD tubing into the inlet fitting. A stop will be felt when the tubing is properly seated in the fitting. Repeat this process for the outlet fitting. Route the outlet tubing to an atmospheric drain, or sump.

Remove the 1/8-inch NPT to 1/8-inch Tube fitting at the top of the Sample Inlet Device. This fitting has Teflon® two-piece ferrule. Take care not to lose it, or over-tighten. It can be reused numerous times if not over-tightened.

Insert the sample pick-up line into the fitting and attach the 60 micron filter to the end of the sample line. Secure the fitting to the Sample Inlet Device. Position the sample pick-up line/filter at approximately mid-way in the Sample Inlet Device. Gently tighten (do not over-tighten) the 1/8-inch nut on the fitting.

Apply sample to the system and check for leaks. Insure that the sample from the outlet of the Sample Inlet Device is flowing freely to the drain.

## 4.7 Optional In-Line Filter

In some applications, the addition of first-stage filtration may be necessary before the Sample Inlet Device. A 40-mesh strainer is available, but not included with the analyzer. The 40-mesh strainer may be installed at any point in the sample line prior to the inlet of the Sample Inlet Device. However, a position in close proximity to the inlet of the Sample Inlet Device is recommended to prevent the build-up of contamination in the sample line after the strainer.

## 4.8 Optional Sample Inlet Devices and Systems

The Model 3017M Chlorine Analyzer is not absolutely dependent upon a pressurized stream of water. For instance, a sample may be placed in a container and the sample inlet tube submerged in it.

As long as the sample inlet tube shown in Figure 4.7 is submersed in a representative sample, the Sample Pump on the instrument will draw the sample into the instrument. Therefore, any number of different sample devices can be used on the Model 3017M. The sample inlet tube may be inserted into a flowing stream of water. As long as the recommended distances from the instrument to the sample point are followed and the sample tube is always fully submersed in water, and steps are taken to prevent clogging, the Sample Pump should draw water into the analyzer.

## 4.9 Electrical Connections

The cable glands on the left-hand-side of the analyzer will accept cable diameters from 5.8 mm (0.23 in) to 13.9 mm (0.53 in). All terminals are designed to accept wires in the range

of 14-28 AWG. All wires should be stripped to a length of 6.35 mm (1/4- inch). Wire ferrules have been found to be particularly useful with the terminal block in the analyzer. The power and RS 485/4-20 mA connections are made through the cable glands that are supplied with the analyzer. The power and RS 48/4-20 mA cable glands can be found on the left-hand-side of the analyzer. See Figure 4.4.

If alternate cable glands are desired, use sealing-type conduit fittings to maintain IEC 529 IP 66 rating. Alternatively, hard conduit and conduit seals may be used for power and RS 485/4-20 mA connections.

### 4.9.1 Power Connections



#### **DANGER**

***Electrocution hazard. Only qualified personnel should conduct the tasks described in this section of the manual. Connect equipment in accordance with national, state and local electrical codes. When working inside of the enclosure power should be disconnected prior to entry.***

Power, signal, relay and alarm connections are made at the terminal block inside the enclosure on the left-hand-side of the analyzer. For industrial applications, the national electrical codes of most countries may require that AC service be hard-wired and contained in rigid conduit systems. The Model 3017M has been designed to conform to that requirement. Refer to Figure 4.4.

Additionally, electrical and instrumentation standards require a local means of removing power from a device. The Model 3017M does not have a power on/off switch. However, a fusible link on the Terminal Block can be used to remove power from the analyzer. An external means of removing power from the analyzer may be necessary.

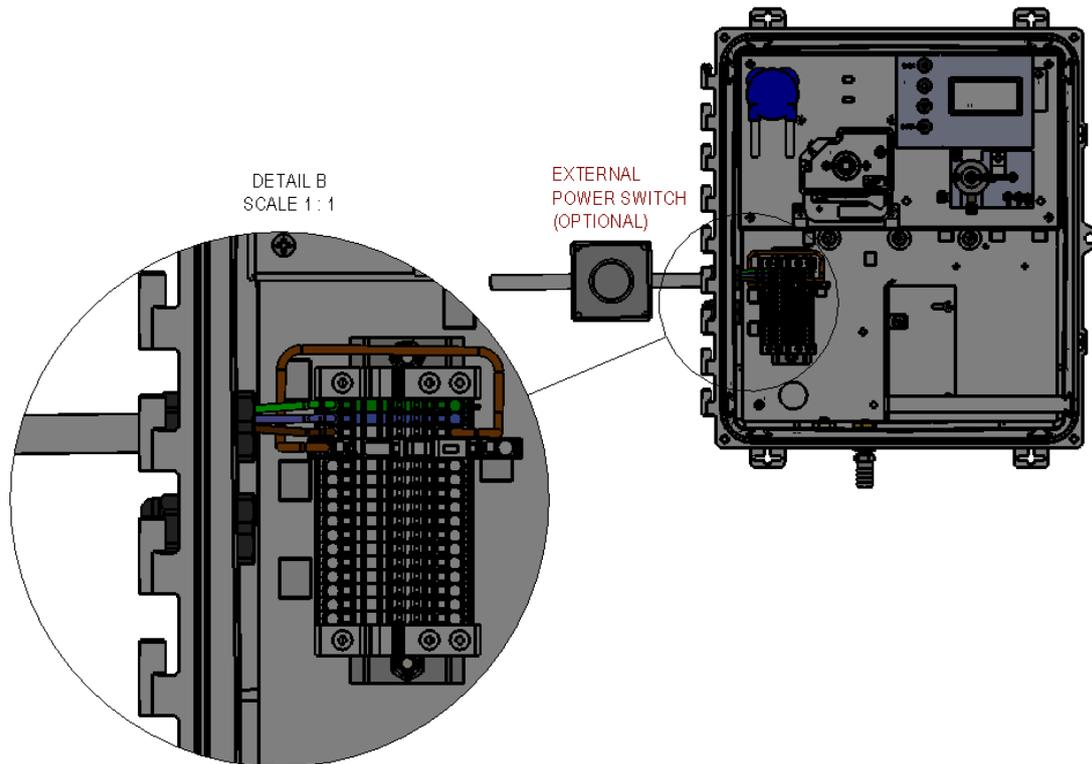

Figure 4.8 Model 3017M showing terminal block and external power switch

In applications where power cords are allowed by local electrical code and power surges and transients are not a concern, a power cord with three 18 gauge wires can be used. The cable gland on the left-hand-side of the analyzer is compatible with most, standard power AC power cords.

#### 4.9.2 Wiring the Analyzer



##### **DANGER**

***Electrocution hazard. Insure that the power cord is not connected to outlet, or other power source.***



The Model 3017M can accept either 115 VAC or 230 VAC. There is no voltage selector switch.

The Model 3017M uses WAGO® connectors for power, signal, and alarm connections. See Figure 4.9, Table 4.1 and Table 4.2. The individual connector blades are opened by inserting the tip of a narrow, flat-blade screwdriver into the square opening of the connector. Insert the screwdriver tip until it bottoms-out in the connector. Insert the stripped wire and remove the screwdriver. Gently pull on the wire to insure that the blades of the connector have secured the wire.

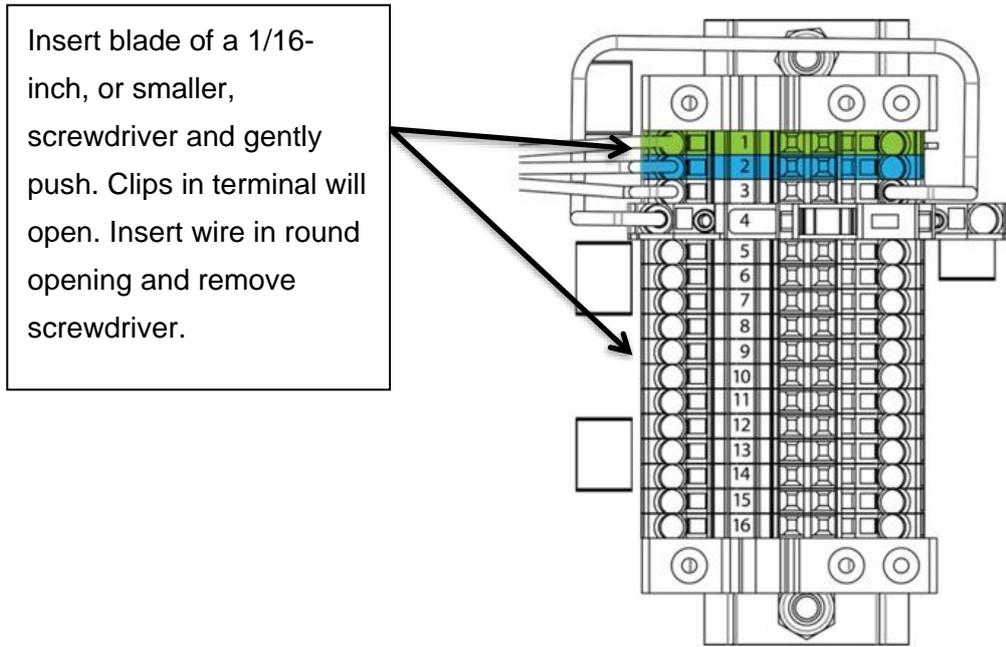

Figure 4.9 Terminal Block

Position	Connection/Purpose	Wire Color
1	AC Earth	Green/Green Yellow
2	AC Neutral (Line 2)	White/Blue
3	AC Line (Line 1)	Black/Brown
4	Fusible Link (0.5A)	Brown
5	RS 485-A	White
6	RS 485-B	Grey
7	RS 485 RTN	Purple
8	4-20 mA (+)	Blue
9	4-20 mA (-)	Green
10	ALARM 1 (NC)	Yellow
11	ALARM 1 (COM)	Orange
12	ALARM 1 (NO)	Red
13	ALARM 2 (NC)	Brown
14	ALARM 2 (COM)	Black
15	ALARM 2 (NO)	Pink
16	SPARE	

Table 4.1 Position and purpose for each wire on the 3017M Terminal Block

Connect the unpowered, AC power wires to the terminal block as follows:

1. If using a power cord, strip the outer sheath back 10.2 cm (4-inches). Strip each, individual wire back 6.35 mm (1/4-inch). If using individual wires, strip each wire back 6.35 mm (¼-inch).
2. Remove the nut from the cable gland, and route the power cord through the nut and cable gland into the enclosure.
3. Pull the power cord back so that the end of the sheath aligns with the inside edge of the cable gland in the enclosure. This insures that the nut will tighten on the sheath and seal the connection.
4. Connect the three wires to the proper connector using the information in Table 4.1 and Figure 4.9.

Regional Wire Color	Earth Ground	Line 1 (Hot)	Line 2 (Neutral)
North America	Green	Black	White
IEC	Green with yellow tracer	Brown	Blue

Table 4.2 Main Power Terminal Wiring

### 4.9.3 RS 485

The RS-485 full-duplex (3-wire) digital interface operates with differential levels that are not susceptible to electrical interferences. This is why cable lengths up to 914 m (3,000 ft). can be implemented. The last device on each bus may require terminating with a 120 ohm resistor to eliminate signal reflection on the line. Do not run RS-485 cables in the same conduit as mains power. Set-up of the RS-485 Appendix A: Programming Guide.

### 4.9.4 Analog Output (4-20 mA)

The 4-20 mA output is driven by a 12 VDC power source or may be driven by an external power source by changing the jumper positions on JP3 and JP4 on the Main Control PCA. If the 4-20 mA output is driven by an external source, reverse the polarity of the connectors at the terminal block, see

Table 4.1, in addition to changing the jumper position on the Main Control PCA. The default positions are: JP3: pins 1&2. JP4: pins 1&2. For external power, the jumper positions are as follows: JP3 pin 1 to JP 4 pin 1, and JP3 pin 2 to JP 4 pin 2. The 4-20 mA output will drive loads from 0 to 600 Ohms. Transformer isolation is provided on the analyzer. Do not run 4-20 mA cables in the same conduit as mains power.

### 4.9.5 Alarm (Relay) Connections

**CAUTION**

**Fire hazard. Current to the relay contacts must be limited to 6A resistive. A method to remove power from the relays locally must be available in case of an emergency or for servicing the analyzer.**

The analyzer has two potential-free, single pole-double throw Alarm Relays. The relays are rated at 30 V, 6A. The Alarm connections are labeled Normally Open (NO), Normally Closed (NC) and Common (C). The alarm is configured fail-safe; the normal condition is with power applied to the analyzer and in a non-alarm condition.

### 4.9.6 Reagent Preparation

The 3017M requires two reagents; a buffer solution and an indicator solution that contains the DPD powder. These reagents must be mixed and installed in the analyzer enclosure. The buffer and indicator solutions are mixed in 500 ml bottles that can be found in either: KIT-FREE CHLORINE, order number 860161, or KIT-TOTAL CHLORINE, order number 860166. Each kit will contain the items below. The containers in the respective kits are clearly marked. The buffer and indicator bottles are installed on the right-hand side of the analyzer enclosure with the BUFFER in the farthest, right-hand position closes to the right side of the enclosure.



The unopened Buffer and Indicator have a shelf-life of five (5) years if they are stored in a cool, dry place. The DPD Powder has a shelf-life of 1.5 years. Once the reagent s are mixed the shelf-life is 30 days at an ambient temperature of 25 °C and 90 days at 5 °C or lower. Ambient temperatures in excess of 30 °C may shorten the lifetime of the reagents.

1. Diphenylenediamine (DPD) reagent in a small amber glass bottle
2. The 500 ml **Buffer reagent** pre-charged with dry powder with a fill line
3. The 500 ml **Indicator reagent** pre-charged with dry powder with a fill line
4. Instructions for use



1 liter of deionized water (not included) is needed to prepare the reagents. If deionized water is not available, then use water that is known to be chlorine free. If necessary, test this water with a handheld meter, or other laboratory test to verify that the water is free of chlorine..

**CAUTION**

The DPD powder must be mixed in the Indicator container.

**Preparing the reagents**

First, prepare the **Buffer** by adding approximately half of the required DI water to the Buffer bottle, capping the bottle, and shaking vigorously until the dry powder inside has completely dissolved.

Once no solids are visible, carefully fill the bottle to the fill line, re-cap it, and mix it again by shaking vigorously for approximately 1 minute, then let stand until the bubbles clear. The **Buffer** is ready for use.

**WARNING**

Indicator reagent is corrosive. Handle with care.

Next, carefully add approximately one-third of the required water to the **Indicator reagent** bottle, cap the bottle securely, and mix it by shaking for approximately 1 to 2 minutes. It is likely there will still be solid material in the bottle. Add a second one-third of the required water and mix again for 1 to 2 minutes. There should be little-to-no solid material left in the bottle. If necessary, mix for an additional 1 to 2 minutes, or until all solid material is in solution.

Transfer the contents of the **DPD** (brown glass) bottle into the **Indicator reagent** bottle, minimizing the amount of material left in the brown bottle. Cap securely and shake the **Indicator** bottle, at which time the color should begin to darken slightly. Carefully add the final amount of water to reach the fill line of the **Indicator reagent** bottle, cap securely and mix again, then let stand until bubbles clear. The **Indicator reagent** is ready for use.

After mixing, the reagents have a shelf life of 30 days at room temperature and 90 days refrigerated at 5 °C.

**Installing the reagents**

1. Replace the plain bottle cap with the Buffer reagent bottle cap (with siphon tube and barbed fitting) and place the prepared, colorless Buffer in the right bottle bay of the 3017M.
2. Replace the plain bottle cap with the Indicator reagent bottle cap (with siphon tube and barbed fitting) and place the prepared, slightly-colored Indicator in the left bottle bay of the 3017M.
3. Carefully connect the pump tubing from the rear reagent pump cassette to the barb on the Indicator reagent bottle and do the same for the front cassette tube with the Buffer bottle.

4. Replace the bottle retaining plate to secure the bottles.

## 4.10 Pump Tubes



### WARNING

**Pinch Point Hazard – While pumps are running it may be possible to become entangled in them while they rotate. Operators should not attempt to replace tubing while the pumps are in operation**



### WARNING

**Leak Hazard – A leak detector is advised to be installed into the analyzer to ensure any leaks will be noticed before causing damage to the analyzer. All barbed connections should utilize cable ties in order to protect from disconnection.**

### 4.10.1 Sample Pump Tube

The analyzer is shipped with the sample pump tube and the reagent pump tubes in place. However, the sample pump tube must be installed on the sample pump rollers.

1. Refer to Figure 4.10.
2. A small package of silicone lubricant, LUBE SILICONE 9017 2 GM, will be located on top of the rollers. This will be used to lubricate the sample pump tube before assembly.
3. Locate the package of silicone grease and cut a small opening across one corner of the package.
4. Apply a thin layer of the silicone grease to the section of the tube that will mount on the roller in the pump. A small bead of approximately 3-mm in diameter should be sufficient. Spread the grease along the section of the tube that will contact the pump tube rollers. Do not apply the grease in excess. There is sufficient grease in the startup kit for multiple pump tube installations. Remove any excess.
5. Hold the pump tube over the roller, and gently push the roller onto the drive shaft of the pump motor. Your fingers should be all that is necessary to insert the sample pump tube onto the rollers of the pump. **DO NOT USE ANY TYPE OF SHARP TOOL TO POSITION THE TUBE. DAMAGE MAY RESULT.**
6. Position the tube so that it connects so that the barb fitting connections on each end are as even as possible. Adjust the tube by gently moving back and forth on the rollers.
7. Install the cover.



Figure 4.10 Installation of the Sample Pump tube

#### 4.10.2 Reagent Pump Tubes

1. The reagent pump tubes are installed in the proper position in the reagent pump. They were connected to the flowcell at the factory. During the preparation of the reagents, the other ends of the pump tubes were connected to their respective reagents.
2. Tension the platens by pushing down on the tensioners. The tensioners will make an audible “click”. Typically, three “clicks” is sufficient tension on the pump tube. Do not overtighten as this may result in premature failure of the tubes.
3. See Figure 4.11.
4. This completes the installation of the reagent pump tubes.



Figure 4.11 Complete Reagent Tube Installation and Platen Tensioning

## 5 Analyzer Startup

### 5.1 Supply the Sample



Double-check all fittings to insure security before applying pressure to the Sample Inlet Device (if used).

Start the sample flowing through the device to which the sample line from the analyzer is attached, or inserted. If this is the Sample Inlet Device, order number 860188, adjust the pressure/flow so that liquid is flowing through the device. Nominally, the flow rate will be in the range of 500 – 1,000 ml/min.

It is not absolutely necessary to have process sample available to start the instrument. If process sample is not available, the sample line from the analyzer may be inserted into a container of water. Fill a container with water that contains some known level of chlorine. This could be checked prior to startup with a handheld meter. Position the container in a

convenient location under, or near, the analyzer and insert the sample line into the container.

In some instances, the analyzer may require a period of 15 to 20 minutes (6 to 8 replicates) before an accurate result is obtained. Allow the analyzer to run for this minimum time period before performing checks with a reference method .

## 5.2 Supply Power to the Analyzer

Insure that the fusible link on the terminal block is open. If an external power switch is installed, close it at this time. Once power is available, close the fusible link. The instrument will proceed to the analyzer Self-Check and come to the **SHUTDOWN** Mode as shown below.

The analyzer will be in a LOCKED state. This means that the user will only have access to the commands in Tier 1 of the firmware. For more information on these commands, and the procedure to UNLOCK the analyzer, refer to the applicable section in Chapter 6, Section 6.7.

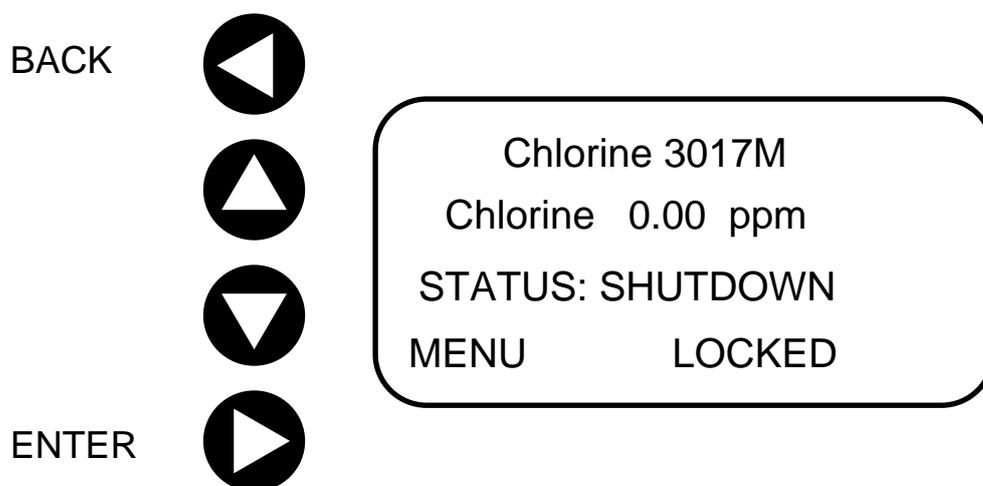

Figure 5.1 3017M Display showing analyzer in locked condition

## 5.3 LANGUAGE SELECTION

English is the default language. Spanish, French, and German are available. If one of these languages is desired, take the following steps.

From the touchpad, select: **MENU<SETUP<LANGUAGE**. Use the ▲ ▼ (UP/DOWN) arrows to select the language of your choice. Use the ◀ (BACK) arrow to exit from this menu. All of the text should now be in the language of your choice.

## 5.4 POWERUP MODE

The default **POWERUP MODE** is **SHUTDOWN**. The **POWERUP MODE** is user-selectable; refer to Chapter 6, Section 6.4 under Tier 3 Commands, **SETUP**. There are other options for the **POWERUP MODE**. These are: **STANDBY** and **STARTUP**. In the event of a power cycle, whether that be intentional or due to a power failure/restoration, the instrument can be programmed to react in any of the three ways described below.

In **STANDBY**, when power is applied, the analyzer will come to the **STANDBY** mode. The Sample and Reagent pumps will occasionally rotate to prevent the tubes from taking a set due to prolonged periods of idleness.

In **SHUTDOWN**, when power is applied, the analyzer will come to the **SHUTDOWN** mode. Power will remain ON; however, the Sample and Reagent pumps will not periodically turn.

The **STARTUP** state consists of the following sequence of events. Each event, or state, will be displayed on the screen.

<b>Event / state</b>	<b>Description</b>
PRIME	The Sample and Reagent pumps will turn at a high speed to prime the lines with liquid.
RINSE	The Reagent pump will stop, and the Sample pump will continue to turn and rinse the Flowcell with sample.
RUN	The Sample pump will return to the speed for normal operation.
AUTOGAIN SET	The Zero Point, sample without reagent, is determined.
INJECT REAGENT	The Reagent pump will start and run for the predetermined amount of time.
INTEGRATE	The analyzer measures the absorption of light that corresponds to the concentration of the sample flowing through the Flowcell.
CALCULATE VALUE	The concentration of the sample is calculated against the calibration curve stored on the analyzer.
DISPLAY VALUE	The concentration of the sample is displayed on the screen

Using the UP or DOWN arrows on the keypad, navigate to the **STARTUP** command. Press ► (ENTER). The analyzer will step through the events as described above and begin the analysis of the sample.

Observe the outlet of the Flowcell. As liquid start to fill the tubes, air will be displaced in the tubes. Since there should be chlorine in the sample, the waste from the Flowcell will turn a pink color during the **PRIME** state.

Two, or three, cycles may be necessary to obtain a stable reading. If bubbles persist after several cycles, insure all tubes are submersed in liquid, and check all fittings for tightness.

The analyzer will continue to measure the sample in the normal operation until a new command is entered, such as, STANDBY. STANDBY state is the preferred state if the analyzer is not actively monitoring a sample stream.

If normal operation is not desired at this point in time, select: **MENU<STANDBY** and place the instrument in the **STANDBY** mode.

After the analyzer is set up to run, the cover should be secured using the 8-32 screws that are included with the mounting hardware in order to prevent unauthorized access to the analyzer by untrained personnel.

## 6 Analyzer Operation

### 6.1 User Interface

As noted in Section 5, the analyzer is typically left in the STANDBY mode unless (1) it is actively monitoring chlorine level in the sample stream, or (2) some other function has been purposely chosen from the list of available functions. See Figure 6.1.

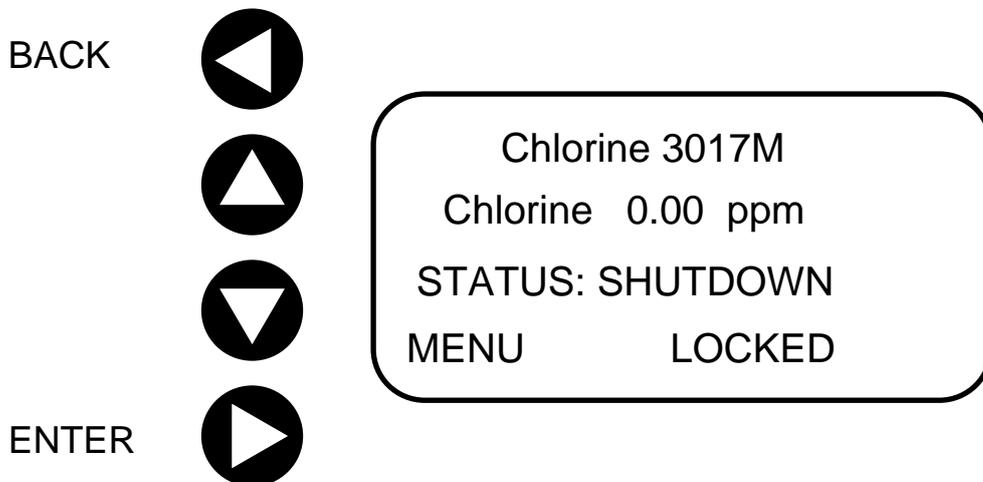

Figure 6.1 Model 3017M HOME Screen

Keys/Arrows		Description
	BACK	The ◀ (BACK) button is used to step back out of a given Tier and ultimately to the HOME screen. If a setting from another section of the firmware is changed, pressing the ◀ (BACK) button will save that setting.
	Up	Used to scroll through menu options or edit parameters/settings
	Down	Used to scroll through menu options or edit parameters/settings.

Keys/Arrows		Description
	ENTER	Accepts an edited value but does not save it, moves deeper into the menu structure, or accepts a menu option

Display Lines		
1	Device	Device type
2	Meas.	Chlorine concentration
3	Status	Provides real-time status of the analyzer during normal and manual operation.
4	Menu	Allows access to commands within each Tier of the firmware. Displays Local Mode and Locked or Unlocked status.

Table 6.1 Analyzer keypad and display with list of functions

## 6.2 Display

The unit has a four-line display and the firmware can be navigated by use of the directional keypad at the left of the display. Figure 6.1 shows the HOME screen and Table 6.1 lists the function of each key and area of the display. This is the desired screen during normal operation. The upper row is used for reporting chlorine levels. The next row indicates the status of the analyzer and the bottom row is divided into two parts. MENU provides access to the next Tier of commands. See Figure 6.2 for a description of each Tier and the commands in each Tier. The right-hand-side of the bottom row indicates if the analyzer settings are LOCKED to unauthorized users.

## 6.3 Touchpad

The touchpad has four buttons that are used to navigate through the various Tiers of firmware commands and other selections. ▲ ▼ (UP/DOWN) buttons move through the possible selections within each Tier. A blinking cursor will appear to indicate which command, or selection, is available when the ► (ENTER) button is pushed. The ◀ (BACK) button is used to step back out of a given Tier and ultimately to the HOME screen. The HOME screen is shown in Figure 6.1.

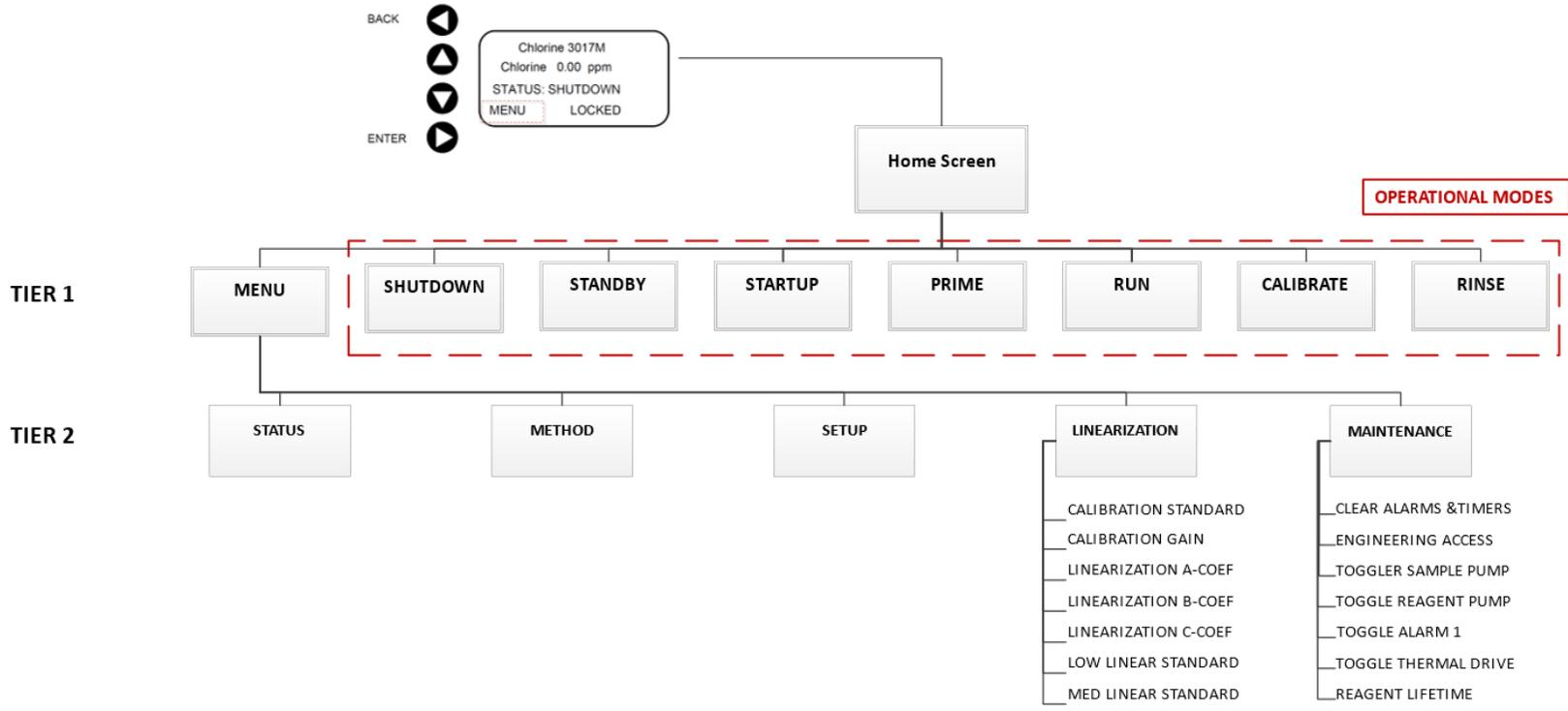

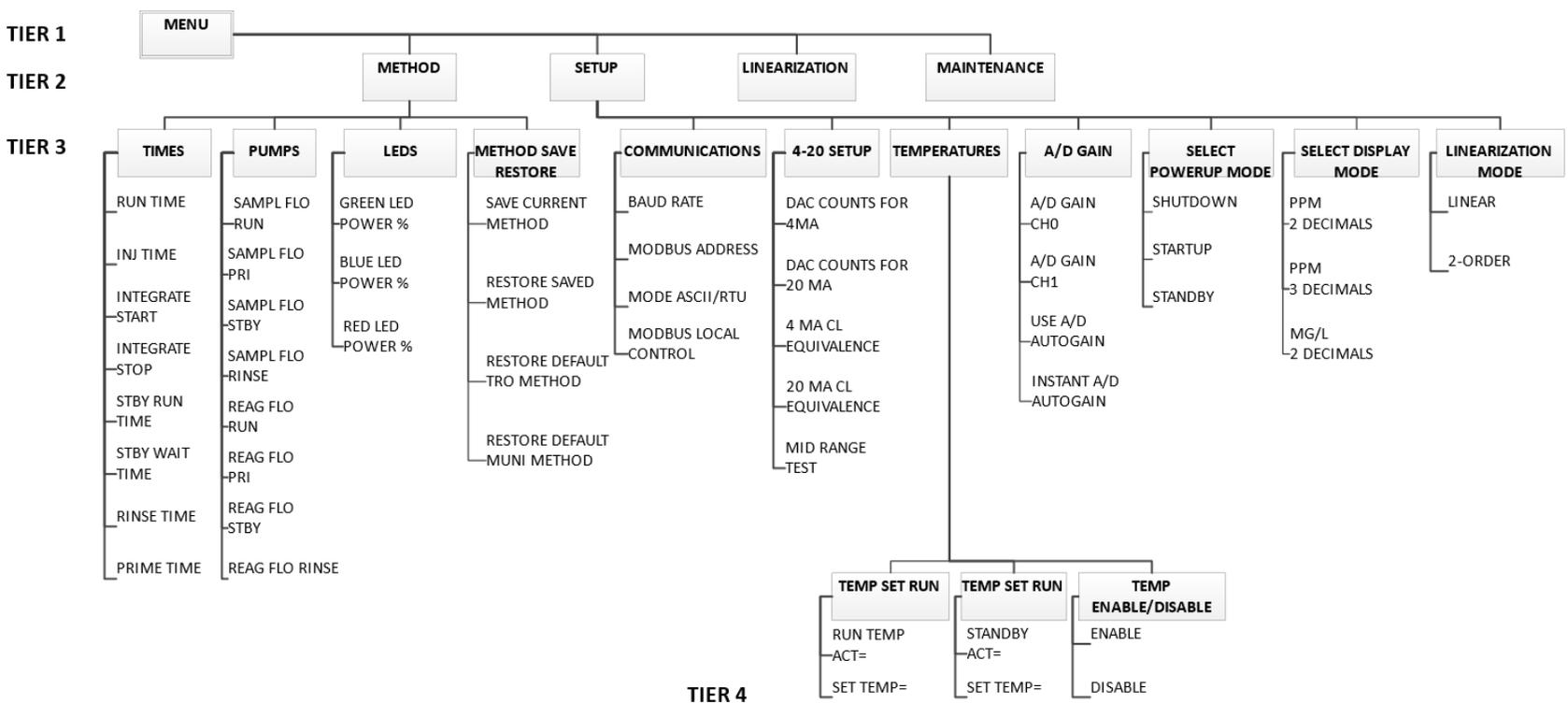

Figure 6.2 Depiction of the tiered structure of the embedded firmware of the 3017M

## 6.4 Description of Firmware Structure and Operation

The firmware on the 3017M has a Tier structure with Tier 1 as the upper-most level. Commands in Tier 1 are routinely used in the operation of the analyzer. Settings in Tier 2, and higher Tiers, are used to configure the analyzer. Refer to the tables below for a brief description of each command or setting. Refer to the appropriate section of this manual for default settings, and procedures for making changes to other settings.

Navigating the firmware is done by use of the four directional arrow keys. Generally, up and down navigate the menus, right confirms a selection, and left exits a menu.

### Tier 1 Selections:

Tier 1	
Option	Description
MENU	MENU is the area of the firmware where method parameters and hardware settings are adjusted. Pressing MENU, when the cursor is present on MENU, moves to the next Tier of commands.
SHUTDOWN	SHUTDOWN is the command that will stop the motion of the peristaltic pumps and prepare the analyzer for storage or shipping.
STANDBY	STANDBY is the command that will place the analyzer in a best-practice offline mode that maintains the peristaltic pump tubing by infrequent rotation of the sample and reagent pump motors.
STARTUP	STARTUP is the command that adjusts gains and applies a fresh calibration, primes the sample and reagent lines, rinses the system, and begins to RUN samples. It is most useful when first powering up the unit or after recalibration.
PRIME	PRIME is the command that turns both the sample pump and reagent pump at a higher-than-normal rate of speed to prime the sample pathway and clear bubbles.
RUN	RUN is the command that starts the analyzer collecting data automatically using current Method parameters.
CALIBRATE	CALIBRATE is the command state that allows the analyzer to be calibrated in the field using a secondary standard.
RINSE	RINSE is the command state that flushes sample from the unit in preparation for storage or shipment, or for any purpose when it is necessary to flush the Flowcell with sample.

### Tier 2 Selections

Tier 2	
Option	Description
METHOD	METHOD is the area of the menu that allows for method parameters to be adjusted. Default Method settings are ideal for almost all applications.

<b>Tier 2</b>	Under MENU
<b>Option</b>	Description
<b>SETUP</b>	SETUP is the area of the menu where communications details and other non-method parameters are set.
STATUS	STATUS is the command that displays current analyzer status in several areas.
LINEARIZATION	LINEARIZATION is the area of the menu where the unit calibration and linearization commands and parameters are located.
MAINTENANCE	MAINTENANCE is the area of the menu where the maintenance commands are located. This is also where you will access ENGINEERING ACCESS to unlock the analyzer.

<b>Tier 2</b>	Under MENU / LINEARIZATION
<b>Option</b>	Description
CALIBRATION STANDARD	CALIBRATION STANDARD sets the nominal concentration of the calibration standard in parts-per-million (mg/L) chlorine.
CALIBRATION GAIN	CALIBRATION GAIN is the gain used for field calibrations, if needed; editing is not recommended.
LINEARIZATION A-COEFF	LINEARIZATION A-COEFF is for informational use and troubleshooting; not altered in normal use.
LINEARIZATION B-COEFF	LINEARIZATION B-COEFF is for informational use and troubleshooting; not altered in normal use.
LINEARIZATION C-COEFF	LINEARIZATION C-COEFF is for informational use and troubleshooting; not altered in normal use.
LINEARIZATION STANDARD LO	LINEARIZATION STANDARD LO is the low calibration standard used for linearization.
LINEARIZATION STANDARD MED	LINEARIZATION STANDARD HI is the high standard used for linearization.
LINEARIZATION STANDARD HI	LINEARIZATION STANDARD HI is the high standard used for linearization.
LINEARIZATION TASK	LINEARIZATION TASK opens a list of four tasks that allow for field linearization by capturing the absorbance of the LO, MED, and HI standards and linearizing with those values. Not recommended for normal use.

<b>Tier 2</b>	Under MENU / MAINTENANCE
<b>Option</b>	Description
CLEAR ALARMS & TIMER	CLEAR ALARMS & TIMER clears any alarms that are present. This includes the Reagent Lifetime alarm.

ENGINEERING ACCESS	ENGINEERING ACCESS unlocks the analyzer for modification from the keypad. The user must scroll up/down till the passcode = 19. To lock the unit to prevent modification the passcode must be set to any number other than "19". When the system is locked, the only functions allowed to be modified from the keypad are RUN MODE and CLEAR ALARMS & TIMER.
SET REAGENT LIFETIME	Enter the time at which an alarm will be displayed that indicates the lifetime of the reagents has expired. The minimum time is 20 days. The maximum time is 99 days.
TOGGLE SAMPLE PUMP	TOGGLE SAMPLE PUMP is a command that toggles the state of the sample pump from off to on or vice versa.
TOGGLE REAGENT PUMP	TOGGLE REAGENT PUMP is a command that toggles the state of the reagent pump from off to on or vice versa.
TOGGLE ALARM/ RELAY 1	TOGGLE ALARM1 is a command that toggles the state of relay 1 from off to on or vice versa.
TOGGLE ALARM/ RELAY 2	TOGGLE ALARM2 is a command that toggles the state of relay 1 from off to on or vice versa.
TOGGLE THERMAL DRIVE	TOGGLE THERMAL DRIVE is a command that toggles the state of the thermoelectric cooler device between ON and OFF. The external heat sink fan is not affected.

### Tier 3 Selections

<b>Tier 3</b>	Under MENU / STATUS – For Troubleshooting (No adjustments)
<b>Option</b>	Description
Refrnc VDC	The instantaneous voltage seen at the A/D convertor from the Reference Channel.
Sample VDC	The instantaneous voltage seen at the A/D convertor from the Sample Channel.
Ref	The Gain Setting for the Reference Channel. (1) is the lowest setting and (8) is the highest setting. The number to the right of the Gain Setting can be used to monitor the Gain change.
Sam	The Gain Setting for the Sample Channel. (1) is the lowest setting and (8) is the highest setting. The number to the right of the Gain Setting and can be used to monitor the Gain change.
L	The low linearization sample and its absorbance.
H	The high linearization sample and its absorbance
M	The medium linearization sample and its absorbance
C	The calibration sample and its absorbance
Liquid Lvl Sensor	The liquid level sensor status: 1 is tripped, 0 is not tripped
Error	The error status: 1 is showing an error flag, 0 is not showing an error flag
Firmware	The two-letter code is the firmware revision, ex. DZ.
PCA	The PCA revision level.
Compiled	The compile date of the firmware.

<b>Tier 3</b>	Under MENU / METHOD
<b>Option</b>	Description
TIMES	TIMES is the section of the method where the durations of the various analysis method states are set.
PUMPS	PUMPS is the section of the method where the pump speeds are set.
RELAYS	Configure Alarm/Relays 1 and 2.
LEDS	LEDS is the section of the method where the power of the light source is set.
METHOD SAVE RESTORE	METHOD SAVE RESTORE is the area of the firmware where update method parameters are saved and re-loaded. Default parameters for either TRO or 3017M mode can be selected.

<b>Tier 4</b>	<b>Under MENU / METHOD / TIMES (See the graphic in Figure 6.2 for more clarity.)</b>
<b>Option</b>	Description
RUN TIME	RUN TIME is the total cycle time for the residual oxidant analysis.
INJECT TIME	INJ TIME sets the time that the reagent pumps turn to inject buffer and indicator reagent during a RUN.
INTEGRATE START	INTEGRATE START sets the time when the detector response begins to be integrated for calculation of peak area.
INTEGRATE STOP	INTEGRATE STOP sets the time when the detector response is no longer integrated for calculation of peak area.
STBY RUN TIME	STBY RUN TIME sets the time that the Reagent Pump will run when the analyzer is in the STANDBY mode. The Sample Pump will automatically run for (1) minute after the Reagent Pump stops.
STBY WAIT TIME	STBY WAIT TIME sets the interval between pump maintenance turns while the analyzer is in Standby mode. See Figure 6.3 for more clarity. The waiting time is set at a fixed 30 minutes, and the running time is typically set at 8 seconds.
RINSE TIME	This is the time that the Sample Pump will run during the STARTUP sequence. The RINSE occurs after PRIME during the STARTUP sequence.
PRIME TIME	This is the length of time that the Sample and Reagent pumps will run during the STARTUP sequence.

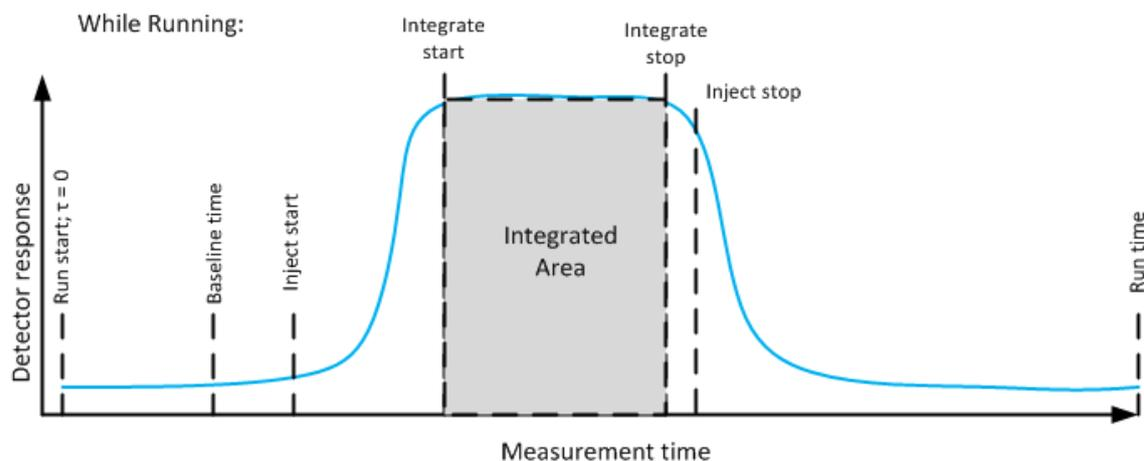

Figure 6.2 A depiction of the state timing for the Chlorine measurement



Figure 6.3 A depiction of the sample and reagent pump activity during the STANDBY state

Tier 4	Under Under MENU / METHOD / PUMPS (See the graphic in Figure 6.2 for more clarity.)
Option	Description
SAMPLE FLO RUN	SAMPLE FLO RUN sets the percentage of maximum flow that the sample pump will turn during the RUN state.
SAMPLE FLO PRI	SAMPLE FLO PRI sets the percentage of maximum flow that the sample pump will turn during the PRIME state.
SAMPLE FLO STBY	SAMPLE FLO STBY sets the percentage of maximum flow that the sample pump will turn during the STANDBY state.
SAMPLE FLO RINSE	SAMPLE FLO RINSE sets the percentage of maximum flow that the sample pump will turn during the RINSE state.
REAG FLO RUN	REAG FLO RUN sets the percentage of maximum flow that the reagent pump will turn during the RUN state.
REAG FLO PRIME	REAG FLO PRI sets the percentage of maximum flow that the reagent pump will turn during the PRIME state.
REAG FLO	REAG FLO STBY sets the percentage of maximum flow that the reagent

<b>Tier 4</b>	<b>Under Under MENU / METHOD / PUMPS (See the graphic in Figure 6.2 for more clarity.)</b>
<b>Option</b>	Description
STBY	pump will turn during the STANDBY state.
REAG FLOW RINSE	REAG FLO RINSE sets the percentage of maximum flow that the reagent pump will turn during the RINSE state.

<b>Tier 4</b>	<b>Under MENU / METHOD / RELAYS</b>
<b>Option</b>	Description
RELAY 1 TYPE	The following entries are available: (0) operates as a timed relay with setpoints entered in RELAY 1 TIME ON and OFF; (1) alarms when chlorine level is below setpoint that is set in RELAY 1 SETPOINT; (2) alarms when chlorine level is above setpoint that is set in RELAY 1 SETPOINT, and (3) operates as a system alarm when an ERROR Flag is set (see MODBUS map).
RELAY 1 SETPOINT	Chlorine concentration level for either low chlorine level, RELAY 1 MODE (1), or high chlorine level RELAY 1 MODE (2).
RELAY 1 ON TIME	The time in the analysis cycle at which RELAY 1 will close when RELAY 1 MODE (0) is set in RELAY 1 MODE.
RELAY 1 OFF TIME	The time in the analysis cycle at which the RELAY 1 will open when RELAY 1 MODE (0) is set in RELAY 1 MODE.
RELAY 2 MODE	The following entries are available: (0) operates as a timed relay with setpoints entered in RELAY 2 TIME ON and OFF; (1) alarms when chlorine level is below setpoint that is set in RELAY 2 SETPOINT; (2) alarms when chlorine level is above setpoint that is set in RELAY 2 SETPOINT, and (3) operates when an ERROR Flag is set (see MODBUS map).
RELAY 2 SETPOINT	Chlorine concentration level for either low chlorine level, RELAY 2 MODE (1), or high chlorine level RELAY 2 MODE (2).
RELAY 2 ON TIME	The time in the analysis cycle at which the RELAY 2 will close when RELAY MODE (0) is set in RELAY 2 MODE.
RELAY 2 OFF TIME	The time in the analysis cycle at which the RELAY 1 will open when RELAY MODE (0) is set in RELAY 2 MODE.

<b>Tier 4</b>	<b>Under MENU / METHOD / LED'S</b>
<b>Option</b>	Description
GREEN LED POWER %	GREEN LED POWER % sets the percentage of maximum power that the green LED will be driven.
BLUE LED POWER %	BLUE LED POWER % sets the percentage of maximum power that the blue LED will be driven.
RED LED POWER %	RED LED POWER % sets the percentage of maximum power that the red LED will be driven.

<b>Tier 4</b>	<b>Under MENU / METHOD / METHOD SAVE RESTORE</b>
<b>Option</b>	Description
SAVE CURRENT	SAVE CURRENT METHOD saves updates to method parameters to be

<b>Tier 4</b>	<b>Under MENU / METHOD / METHOD SAVE RESTORE</b>
<b>Option</b>	Description
METHOD	applied as the current method.
RESTORE SAVED METHOD	RESTORE SAVED METHOD restores method parameters to the existing saved method. There is only one active method on the analyzer at a time
DEFAULT METHOD TRO	DEFAULT METHOD TRO restores the method parameters to the factory defaults for operation of the instrument as a Trace Residual Oxidant Monitor and erases the previous method.
DEFAULT METHOD 3017	DEFAULT METHOD 3017M restores the method parameters to the factory defaults for operation of the instrument as a Municipal Chlorine Analyzer and erases the previous method.

<b>Tier 3</b>	<b>Under MENU / SETUP</b>
<b>Option</b>	Description
COMMUNICATIONS	COMMUNICATIONS is the area of setup that sets whether the analyzer is set for MODBUS or LOCAL control, sets the Modbus address and baud rate and toggles between ASCII Modbus and Modbus RTU.
4-20 SETUP	4-20 SETUP is the area of setup that sets the DAC counts for the 4 and 20 mA levels, sets the concentration limits for the output of the 4-20 mA signal, and allows for a test of the output current.
A/D GAIN	A/D GAIN is the area of setup that allows the reference and sample gain at the analog-to-digital converter to be set, as well as an instant autogain to be determined and applied.
LANGUAGE	Choose between English, Spanish, French or German for all text.
POWERUP MODE	This selection allows the choice of STARTUP, STANDBY or SHUTDOWN as the default condition upon the application of power to the analyzer.
DISPLAY MODE	Choose between the following for display of the results; PPM 2 Significant Figures, mg/L 2 Significant Figures or PPM 3 Significant Figures.
LINEARIZATION MODE	Choose between either a linear or 2 <sup>nd</sup> Order curve fitting routine for the linearization of the instrument.

<b>Tier 4</b>	<b>Under MENU / SETUP / COMMUNICATIONS</b>
<b>Option</b>	Description
BAUD RATE	BAUD RATE sets the baud rate that the analyzer will use for communications.
Modbus ADDRESS	Modbus ADDRESS sets the Modbus address of the analyzer for use in Modbus communication.
ASCII/RTU MODE	ASCII/RTU MODE toggles from ASCII communications to RTU and back. The current setting is indicated.
MODBUS LOCKOUT	MODBUS LOCKOUT chooses between MODBUS IS AVAILABLE or UNDER LOCAL CONTROL. This "Modbus Lockout" function restricts the Modbus host from modifying any registers. The host is still able to read all registers. If the host tries to access a write function, the analyzer will issue a "BUSY" Modbus exception. The status of the lockout may be read as ALARM4 bit 15 as well as the display of "LocalMode" on the LCD home screen.

<b>Tier 4</b>	<b>Under MENU / SETUP / 4-20 SETUP</b>
<b>Option</b>	<b>Description</b>
DAC Counts for 4mA	DAC Counts for 4mA sets the DAC counts that correspond to a 4-mA signal.
DAC Counts for 20mA	DAC Counts for 20mA sets the DAC counts that correspond to a 20-mA signal.
4 MA EQUIVALENCE	4 MA CI EQUIVALENCE sets the mg/L equivalence for the 4mA signal. For example, if 4 mA= 1.00 mg/L, the sample concentration will be 1 mg/L when the 4-20 mA system is delivering 4 mA.
20 MA EQUIVALENCE	20 MA CL EQUIVALENCE sets the mg/L equivalence for the 20 mA signal. For example, if 20 mA is set to 5 mg/L, the sample concentration will be 5 mg/L when the 4-20 mA system is delivering 20 mA.
MID-RANGE TEST	MID-RANGE TEST is a command that outputs a fixed current at half of full scale for troubleshooting purposes. For example, if the 4 mA-mg/L value is set to 0 mg/L and the 20 mA value is set to 5 mg/L, pressing this control will force the display, Modbus output and 4-20 mA signal all to 2.5 mg/L.

<b>Tier 4</b>	<b>Under MENU / SETUP / A/D GAIN</b>
<b>Option</b>	<b>Description</b>
A/D GAIN CH0	The analog-to-digital (A/D) converter has a variable gain amplifier stage at the input. The gain ranges from 1X to 128X by powers of 2. A/D GAIN CH0 is the amount of amplification applied to channel 0, the sample photometric detector.
A/D GAIN CH1	The analog-to-digital (A/D) converter has a variable gain amplifier stage at the input. The gain ranges from 1X to 128X by powers of 2. A/D GAIN CH1 is the amount of amplification applied to channel 1, the reference photometric detector.
USE A/D AUTOGAIN	Since the photometric detection process measures the decrease in light through the photocell as the target analyte is being measured, it is advantageous to have the photocell at close to a full-scale reading when no analyte is present for the greatest sensitivity. The USE A/D AUTOGAIN setting automatically sets the gain on the photocells to ensure maximum gain within the range of the amplifiers. 1 = ON; 0 = OFF. It is recommended that this setting always be ON.
INSTANT A/D AUTOGAIN	This task runs the Autogain routine. If USE A/D AUTOGAIN is on, this routine is run at analyzer startup.

<b>Tier 4</b>	<b>Under MENU / SETUP / LANGUAGE</b>
<b>Option</b>	<b>Description</b>
ENGLISH	All text in English
SPANISH	All text in Spanish
FRENCH	All text in French
GERMAN	All text in German
ITALIAN	All text in Italian

<b>Tier 4</b>	<b>Under MENU / SETUP / POWER UP MODE</b>
<b>Option</b>	Description
SHUTDOWN	Upon application of power, the analyzer will proceed to the SHUTDOWN Mode.
STANDBY	Upon application of power, the analyzer will proceed to the STANDBY Mode.
STARTUP	Upon application of power, the analyzer will proceed to the STARTUP Mode and begin to analyze the sample stream, or sample, to which the sample line is connected.

<b>Tier 4</b>	<b>Under MENU / SETUP / SELECT DISPLAY MODE</b>
<b>Option</b>	Description
ppm 2 Decimals	Displays the result as parts-per-million (ppm) with two significant figures after the decimal point.
mg/L 2 Decimals	Displays the result as milligrams per Liter (mg/L) with two significant figures after the decimal point.
ppm 3 Decimals	Displays the result as parts-per-million (ppm) with three significant figures after the decimal point.

<b>Tier 4</b>	<b>Under MENU / SETUP / LINEARIZATION MODE</b>
<b>Option</b>	Description
LINEAR	Applies a LINEAR curve fit to the calibration regardless of mode of operation (TRO or 3017). The default setting for TRO is LINEAR. The default setting for 3017M is 2-ORDER.
POLY-2	Applies a 2 <sup>nd</sup> Order curve fit to the calibration regardless of mode of operation (TRO or 3017). The default setting for TRO is LINEAR. The default setting for 3017M is POLY-2 (2-ORDER).

<b>Tier 3</b>	<b>Under MENU / LINEARIZATION</b>
<b>Option</b>	Description
LINEARIZATION TASK	Locks the absorbance readings for the determination of the LOW, MED, and HI coefficients for either a linear or 2 <sup>nd</sup> Order curve fit. Once the absorbance readings are determined, depressing RELINEARIZE will lock these absorbance readings and determine coefficients.

<b>Tier 4</b>	<b>Under MENU / LINEARIZATION TASK</b>
<b>Option</b>	Description
LOCK LOW	LOCK LO — This task captures the absorbance for the low linearization standard for use later in linear or 2 <sup>nd</sup> Order curve fitting.
LOCK MED	LOCK MED — This task captures the absorbance for the medium linearization standard for use later in linear or 2 <sup>nd</sup> Order curve fitting.
LOCK HI	LOCK HI — This task captures the absorbance for the high linearization standard for use later in linear or 2 <sup>nd</sup> Order curve fitting.

Tier 4	Under MENU / LINEARIZATION TASK
Option	Description
RELINERIZE	RELINERIZE — This task determines the linearization coefficients based on data previously captured using the above three commands for either a linear or 2 <sup>nd</sup> Order curve fit, and locks those coefficients.

### 6.5 Unlocking/Locking the Analyzer

Adjustment to the following analyzer settings in Sections 6.6, 6.7 and 6.8 requires unlocking the analyzer. **ENGINEERING ACCESS** unlocks the analyzer for modification of settings from the keypad. When the system is locked, the only functions that can be accessed from the keypad are **TIER 1** options.

**ENGINEERING ACCESS** is a Tier 2 option. Navigate to it as follows; select: **MENU<MAINTENANCE<ENGINEERING ACCESS.**

Use the ▲ ▼ (UP/DOWN) buttons to enter the Passcode: 19. Use the ◀ (BACK) button to save and exit from this level. The display should appear as shown in Figure 6.1.

After all of the settings have been modified, navigate back to **ENGINEERING ACCESS.** Use the ▲ ▼ (UP/DOWN) buttons to enter any value for the Passcode other than 19. Use the ◀ (BACK) button to save and exit from this level.

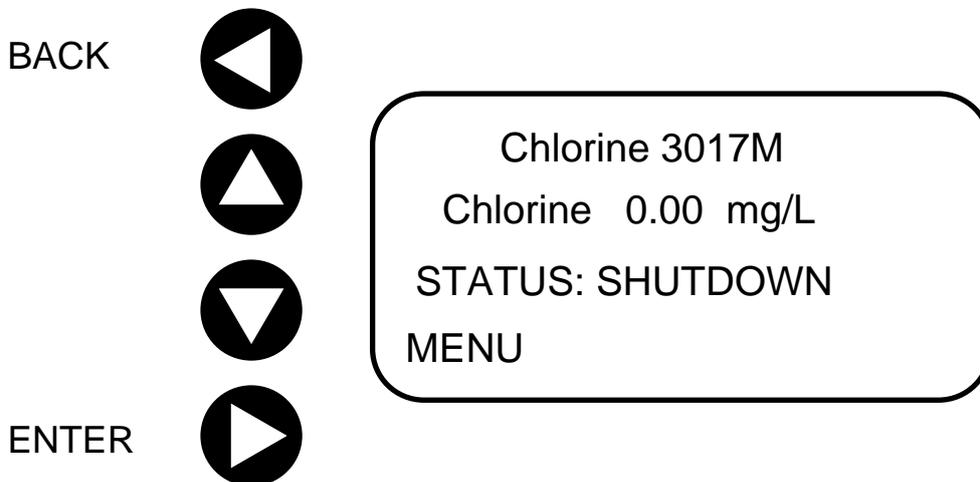

Figure 6.1 3017M Display showing analyzer in Unlocked condition

### 6.6 Method Settings

Section 7 provides a detailed description of the default Method settings in the Model 3017M firmware. The Model 3017M is tested and shipped with default settings for the various states. These default settings are appropriate for most applications. However, if a setting is changed, this changed must be saved to the new Method. Select:

**MENU<METHOD<METHOD SAVE RESTORE<SAVE CURRENT METHOD.** If this step is not taken, the changes to the Method will be lost at the next power cycle.



If for any reason, you are unsure as to what may have, or have not, been changed and you wish to start the process over from the default settings, select: **MENU<METHOD<METHOD SAVE RESTORE< DEFAULT METHOD 3017.**

## 6.7 Setting the 4-20 mA Output

Navigate as follows: **MENU<SETUP<4-20 SETUP.** The analyzer has a default, full-scale output of 5.00 mg/L. If another full-scale range is desired, set that value prior to adjusting the 4-20 mA output. **Select: 20 mA Cl Equivalence** and change the full-scale output if necessary using the ▲ ▼ (UP/DOWN) buttons on the keypad.

Depress the BACK button and select: **DAC Counts for 4 mA.** The analyzer will output 4 mA. Read the output with a properly calibrated voltmeter at the analyzer, datalogger, or other remote device or location. If the analyzer signal is being connected to some other device that may be a considerable distance from the analyzer, then the signal output should be measured at that location. Using the ▲ ▼ (UP/DOWN) buttons, adjust the 4 mA output until the reading is within specification.

Depress the ◀ (BACK) button and select: **DAC Counts for 20 mA.** The analyzer will output 20 mA. Read the output with a properly calibrated voltmeter at the analyzer, datalogger, or other remote device or location. If the analyzer signal is being connected to some other device that may be a considerable distance from the analyzer, then the signal output should be measured at that location. Using the ▲ ▼ (UP/DOWN) buttons, adjust the 20 mA output until the reading is within specification.

Depress the BACK button then the DOWN button and navigate to Mid-Range Test. The analyzer will output 12 mA. It will be necessary to save these settings in the Method. Save the Method settings. Save the Method settings: **MENU<METHOD<METHOD SAVE RESTORE<SAVE CURRENT METHOD.**

## 6.8 Setting the Alarm/Timed Event Relays

### 6.8.1 Setting the Alarm Relays with the Keypad

The analyzer has two potential-free relays (Relay 1 and Relay 2). The relay settings are accessed through **MENU<METHOD<RELAYS.** The relays may be assigned to one of the

functions below. Only one function can be assigned to each relay. The relays are rated for 30 VDC, 6A. They are not designed for high voltage, or alternating current applications.

- **Low Concentration:**  
The alarm is triggered if the chlorine concentration is less than or equal to the setpoint. The setpoint has a range of 0.00 to 5.00 mg/L.
- **High Concentration:**  
The alarm is triggered if the chlorine concentration is greater than or equal to the setpoint. The setpoint has a range of 0.00 to 5.00 mg/L.
- **System Error:**  
Operates as a system error when an Error Flag is set. Refer to the Modbus Map in Appendix A for list of error flags.
- **Timed Event:**  
Operates as a timed relay. The relay can be activated during the time between RUN start and approximately 10 seconds before reagent injection. The relay can be deactivated during the time between RUN start and approximately 10 seconds before reagent injection.

Perform the following steps to assign a function to Relay 1 or Relay 2.

1. Select: **MENU<METHOD<RELAYS**
2. Select: **RELAY 1 MODE**

The **MODE** selection determines how the relay will operate. The choices are as follows:

1. (0): Operates as a timed relay with setpoints entered in **RELAY 1 TIME ON** and **OFF**.
2. (1): Alarms when the chlorine concentration is below, or equal to, the setpoint that is set in **RELAY 1 SETPOINT**.
3. (2): Alarms when the chlorine concentration is higher, or equal to, the setpoint that is set in **RELAY 1 SETPOINT**.
4. (3): Operates as a System Alarm when an Error Flag is set.
5. Save the Method settings: **MENU<METHOD<METHOD SAVE RESTORE<SAVE CURRENT METHOD**.

When the relays are configured as concentration/error alarms, the relay is activated when the condition occurs. Either relay may be activated on a high chlorine, a low chlorine, or Error flag. Alarm relays can be used to control chemical feeds as ON/OFF control, by using them as a high or low alarm set point through an auxiliary device such as Programmable Logic Controller (PLC).

## 6.8.2 Setting the Alarm Relays through MODBUS

The items available for viewing under Status are covered in Section 7 and will not be covered in detail in this section. However, the information provided under Status is very important if troubleshooting is necessary.

1. The alarm is set through Modbus. The alarm type is register 16: 0=off, 1=Low Alarm, 2=High Alarm, & 3+ Error Alarm. The Alarm set point is a floating variable assigned to registers 17 & 18.
2. If the Alarm Type is set to 1, then the alarm will go off if the Cl concentration is below the set point. If the Alarm Type is set to 2, then the alarm will go off if the C concentration is above the set point.
3. If the Alarm is set to 0, then the alarm output acts like a time relay according to TimeValve1On (Modbus 33) and TimeValve1Off Modbus 34).

When the relays are configured as concentration/error alarms, the relay is activated when the condition occurs. Either relay may be activated on a high chlorine, a low chlorine, or Error flag. Alarm relays can be used to control chemical feeds as ON/OFF control, by using them as a high or low alarm set point through an auxiliary device such as a Programmable Logic Controller (PLC).

## 6.9 Calibration

The Model 3017M Chlorine Analyzer is factory calibrated. The instrument does not require calibration unless it is specified by your regulatory agency or standard operating procedure.



Please note down the linearization coefficients of the last valid calibration, in particular the factory calibration.

After an incorrect calibration, you can use it to restore the last valid calibration.

You can find the 3 linearization coefficients in:

Menu < Linearization < Linearization A-COEF/Linearization B-COEF/Linearization C-COEF.

Follow the instructions in Sections 6.9.1 and 6.9.2 for calibration of the analyzer.

## 6.9.1 Calibration with a Known Standard



### CAUTION

**Chemical exposure hazard: Always review the Safety Data Sheets (SDS) that accompanies any chemical to familiarize yourself with proper handling precautions, emergency procedures, and waste disposal. Protective eye wear is recommended when handling any chemical.**

1. Place the analyzer in the **STANDBY** mode.
2. Prepare a zero chlorine solution by placing 1 liter of normal water on a heated stirring plate and heat for 24 hours, while stirring, at just under 100 °C. It is not necessary to boil the water. Otherwise, obtain 1 liter of chlorine-free, demineralized water.
3. Using the water from Step 1, prepare a chlorine standard solution with a value of 3 to 5 mg/L. Determine the value of the standard to the nearest 0.01 mg/L using a EPA approved reference method.
4. Select: **MENU<LINEARIZATION<CALIBRATION STANDARD**. Enter the value of the calibration standard that was determined in Step 3. Use the ◀ (BACK) button to exit back to the **HOME** screen.
5. Remove the 1/8-inch sample line from the bottom of the analyzer that is connected to the Sample Inlet Device, and connect the piece of 1/8-inch tubing that can be found with the instrument.
6. Place the line in the standard and from the keypad select: **RINSE**. Rinse the Sample Pump Tube and Flowcell for 2 minutes.
7. Select: **STANDBY** and allow the Sample Pump to come to a complete stop.
8. Select: **STARTUP**. The analyzer will enter the normal STARTUP cycle, and proceed to normal RUN state. Allow the analyzer to run on this standard for approximately 5 cycles, or 10 minutes.
9. While the analyzer is running the standard, select: **CALIBRATE**. The analyzer will query: **CALIBRATE TO LAST DISPLAYED VALUE**. Select: ▶ (ENTER).
10. The displayed value on the display will change to the calibration standard value. The analyzer is now calibrated.
11. Save the Method settings: **MENU<METHOD<METHOD SAVE RESTORE<SAVE CURRENT METHOD**.

## 6.9.2 Calibration by Comparison



Grab samples are used in this calibration technique. The chlorine concentration in the process stream should be stable and the grab samples

should be immediately analyzed.

Calibration by comparison involves analyzing the sample stream with a reliable, accurate laboratory method, such as a DPD spectrophotometric, or amperometric titration method. If a handheld meter is used for the calibration, as is typically the case, then it is suggested that three, successive measurements of the process stream are taken with results within 0.03 mg/L of one another. Use the average value of the three readings for the calibration. The response of the 3017M is then set to match this result. Setting the calibration at a concentration below the mid-point of the calibration range 0 to 5 mg/L may result in loss of accuracy at the upper end of the calibration range.

Perform the following steps:

1. Leave the analyzer in the **RUN** mode.
2. Obtain the grab sample as close as possible to the analyzer. If the Sample Inlet Device is used and the drain line is accessible, this could be a good sampling point. Immediately perform the laboratory analysis or take the handheld meter reading. If the latter technique is used, take three measurements in quick succession. These measurements should be within 0.03 mg/L of each other. Use the average value.
3. Select: **MENU<LINEARIZATION<CALIBRATION STANDARD**. Enter the value of the calibration standard that was determined in Step 2. Use the ◀ (BACK) button to exit back to the **HOME** screen.
4. From the Main Menu, use the ▲ ▼ (UP/DOWN) buttons and select: **CALIBRATE**. The analyzer will query: **CALIBRATE TO LAST DIPLAYED VALUE**. Select: ▶ (ENTER).
5. The displayed value on the display will change to the calibration standard value. The analyzer is now calibrated.
6. Save the Method settings: **MENU<METHOD<METHOD SAVE RESTORE<SAVE CURRENT METHOD**.

## 7 Default Configuration and Method Settings

Section 6 provides a detailed description of the various Tiers of commands and settings in the Model 3017M firmware. The Model 3017M is tested and shipped with default settings for the various functions. These default settings are appropriate for most applications.



Adjustment of the settings found in the various Tiers of the Model 3017M firmware are only accessible if the instrument is in an UNLOCKED status.

Refer to **MAINTENANCE<ENGINEERING ACCESS**.

## 7.1 Method Settings

The Method settings are described in Section 6. These settings are appropriate for all applications. For reference, the default settings are listed here.

### 7.1.1 Times

Parameter	Time (seconds)	Explanation
RUN TIME	160	Cycle time. Sample to sample analysis time.
INJ TIME	56	Amount of time that reagent pump runs during a measurement cycle.
INTEGRATE START	40	The time, in the cycle, when the integration of the photodiode response starts.
INTEGRATE STOP	56	The time, in the cycle, when the integration of the photodiode response stops.
STBY RUN TIME	8	The amount of time that the reagent pump will run when the analyzer is in STANDBY mode; the sample pump will run for one minute after reagent pump stops.
STBY WAIT TIME	1800	The time between each STANDBY pump cycle.
RINSE TIME	90	The amount of time that the analyzer rinses the flowcell with sample during the STARTUP sequence.
PRIME TIME	60	The amount of time that the analyzer primes the sample during the STARTUP sequence.



Under almost all circumstances, it is not necessary to adjust any of these times. If any of these times are changed, it will be necessary to use the **METHOD SAVE RESTORE** function, and **SAVE CURRENT METHOD**.

### 7.1.2 Pumps

Parameter	Flow Rate (µL/min)	Explanation
SAMPLE FLO RUN	1,000	Sample flow rate during the RUN cycle.
SAMPLE FLO PRI	2,086	Sample flow rate during in the PRIME mode.
SAMPLE FLOW STBY	2,086	Sample flow rate in STANDBY mode.
SAMPLE FLO RINSE	2,086	Sample flow rate in the RINSE mode.
REAG FLOW RUN	25	Reagent flow rate during the RUN cycle.
REAG FLO PRIME	400	Reagent flow rate during the PRIME cycle.

REAG FLO STBY	40	Reagent flow rate during the STANDBY mode.
REAG FLO RINSE	80	Not used. Reagent pump is OFF during RINSE.

### 7.1.3 LED's



The Model 3017M has three LED's; Green, Blue and Red. Only one of those wavelengths is used at any given time. The selection of the wavelength is application dependent. The selection of wavelength, or the LED Power setting should not be changed under any circumstances.

LED SETTING (SELECTION)	Default Setting
GREEN LED POWER %	(18) for 3017M
BLUE LED POWER %	Not Used in normal operation for 3017M
RED LED POWER %	Not Used in normal operation for 3017M

## 7.2 Setup

The Setup menu contains important settings that can be used to configure the Model 3017M for Modbus control, or other control systems. These settings are mainly found under **COMMUNICATIONS** and **4-20 mA SETUP**. The settings listed are the default settings.

### 7.2.1 Communications

Parameter	Default Setting
Baud Rate	9600
Modbus Address	1
Mode ASCII/RTU	RTU
Modbus Local Control	MODBUS IS AVAILABLE

### 7.2.2 4-20 mA Setup

Parameter	Default Setting
DAC Counts for 4 mA	SET DAC = 28E9 CNTS
DAC Counts for 20 mA	SET DAC = CC3D CNTS
4 mA CI Equivalence	4 mA SET = 0.000 mg/L
20 mA CI Equivalence	20 mA SET = 5.000 mg/L
Mid-Range Test	See below



The DAC counts shown above are the default values. The 4 and 20 mA outputs are not adjusted at the factory as part of the checkout procedure. The DAC count values are different than the default values for every instrument. The Mid-Range test value will depend on the adjustment of the 4 and 20 mA output settings.

### 7.3 Status

The items available for viewing under Status are covered in Section 5 and will not be covered in detail in this section. However, the information provided under Status is very important if troubleshooting is necessary.

### 7.4 Linearization

The entries under Linearization allow for field calibration of the Model 3017M, field linearization of the Model 3017M and viewing of the Calibration Gain. The Model 3017M is linearized and calibrated at the factory as part of the checkout process; therefore, each analyzer will have a unique set of linearization coefficients. In most cases, it is not necessary to recalibrate, or re-linearize, the Model 3017M. A complete procedure for linearization will be covered in the Maintenance Section, Section 8.

### 7.5 Maintenance

There are no default settings for the command under Maintenance except for **ENGINEERING ACCESS**. The default value for **ENGINEERING ACCESS** is (15). This must be set to (19) to gain access to all other settings.

## 8 Maintenance



### WARNING

The processes and procedures in this section involve handling chemicals and working with electrical circuits. Only qualified personnel should conduct the tasks in this section.

### 8.1 Regularly Scheduled Maintenance

#### 8.1.1 Reagent Replacement

The buffer and indicator reagents last approximately one month. New containers will accompany the reagent kit, part number XXXXXX, and should be used for the new reagents. Discard the old containers. Install the new containers as outlined in Section 8.1.2.

The **REAGENT LIFETIME TIMER** should have been set to the desired time; usually between 30 – 40 days. If the time has expired, a warning will be flashing on the **HOME** screen. Navigate to the **MAINTENANCE** screen, and select: **CLEAR ALARMS & TIMERS**.

#### 8.1.2 Pump and Reagent Tube Replacement

The sample and reagent pump tubes will deteriorate over a period of time due to the action of the peristaltic pump rollers and the pressure of the platens. The recommended replacement interval is six months.

#### Replacement Procedure

1. It is not necessary to shut off sample flow at the Sample Inlet Device or disconnect power to the analyzer. However, the analyzer should be in the SHUTDOWN mode to prevent rotation of the Sample and Reagent Pumps that normally occurs in the STANDBY mode.
2. Remove the cover of the Sample Pump. Disconnect the sample inlet and waste lines at the barb fittings. Retain the barb fittings for transfer to the new Sample Pump tube. See Figure 8.1 for installation of the new Sample Pump tube.

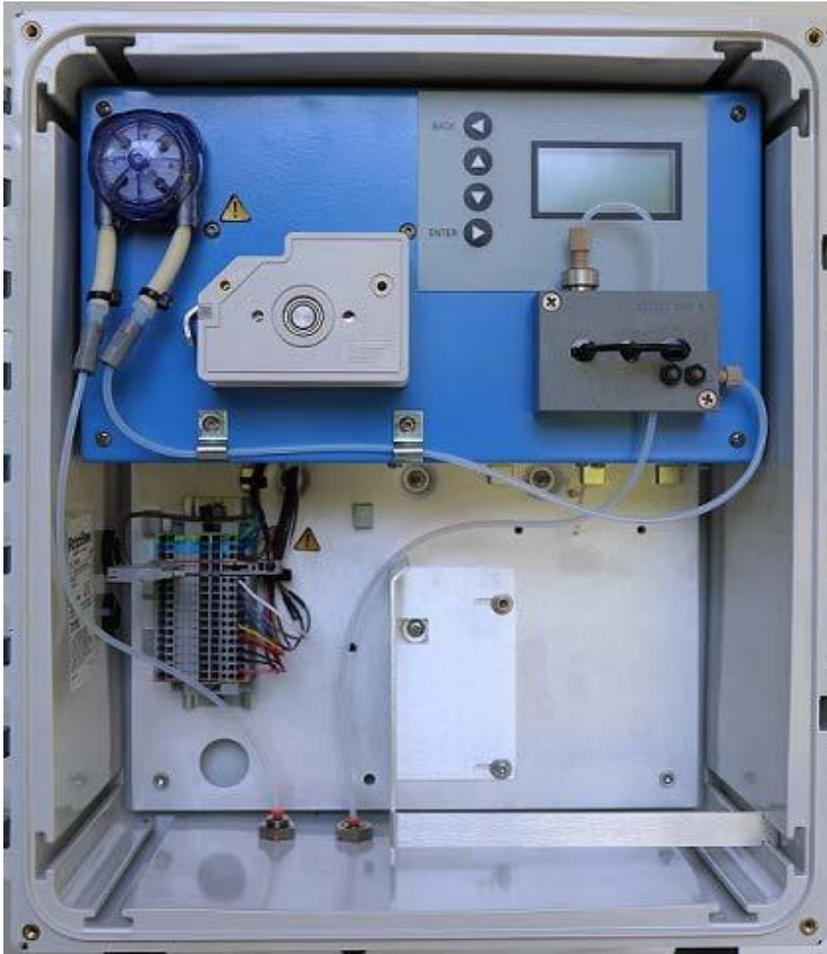

Figure 8.1 Positioning of Sample Pump Tube in Sample Pump

3. Position the tube so that it connects so that the barb fittings on each end are even; they will be adjusted in a later step.
4. Locate the package of silicone grease and cut a small opening across one corner of the package.
5. Apply a thin layer of the silicone grease to the section of the tube that will mount on the roller in the pump. A small bead of approximately 3-mm in diameter should be sufficient. Spread the grease along the section of the tube that will contact the pump tube rollers. Do not apply the grease in excess. There is sufficient grease in the startup kit for multiple pump tube installations. Remove any excess.
6. Hold the pump tube over the roller, and gently push the roller onto the drive shaft of the pump motor.
7. Refer to Figure 8.2.
8. Snap the cover into place so that the roller stays in place.
9. Gently pull the sample tube back and forth so that the ends with the barb fittings are even with each other.

10. Install the sample inlet tube to the left-hand side barb fitting on the Sample Pump. Connect the right-hand-side barb fitting to the line from the sample pump to the flowcell.



Figure 8.2 Completed Pump Tube Installation

11. Disconnect the Buffer and Indicator Pump Tubes from the Flowcell and the reagent bottles. Relieve the pressure on the Reagent Pump platens by pushing up on the tensioners. Refer to Figure 8.3.



Figure 8.3 Installation of Buffer Reagent Tube

12. Release the platens on the reagent pump by pulling back on the tabs that extend at the top and gently pulling downward on the platens. Discard the old Reagent Pump tubes.
13. Locate the replacement pump tubes. There are two tubes; one for the Buffer (blue fitting) and one for the Indicator (red fitting).
14. Hold a pump tube so that the locking tab (red tab) is in your left hand. Attach the end in your right hand to the reagent port marked (B). This will be the port closest to the right-hand-side of the enclosure.
15. Route the tube through an empty cassette, placing the locking tab on the tubing against the left outer edge of the cassette, and then snap it into place in the rear slot.
16. Attach the free end to the barb fitting on the Buffer reagent container.
17. Repeat the three steps above (5, 6, and 7) for the Indicator reagent tube. The Indicator platen/tube will go in the front slot.
18. Tension the platens by pushing down on the tensioners. The tensioners will make an audible “click”. Typically, three “clicks” is sufficient tension on the pump tube.

19. See Figure 8.4.



Figure 8.4 Complete Reagent Tube Installation and Platen Tensioning

20. This completes the installation of the reagent pump tubes.

### Priming the Tubes

The new tubes must be primed with liquid, sample and reagent, before the analyzer is returned to normal operation. Prime the tubes as follows:

1. From the home screen, use the ▲ ▼ (UP/DOWN) buttons and navigate to the **PRIME < ►** (ENTER).
2. Observe the waste line from the Flowcell and once the line is free from bubbles, the lines are primed with liquid.
3. Select: **STANBY < ►** (ENTER). Pump rotation will cease. Inspect all connections for leaks, and if none are found, proceed to Step 4.
4. Select: **STARTUP < ►** (ENTER). The analyzer will begin normal operation.

## 8.2 Unscheduled Maintenance

### 8.2.1 Fuse Replacement

**DANGER**

*Electrocution hazard. Remove power from the instrument when removing or installing the fuse.*

**DANGER**

*Fire hazard. The replacement fuse must be of the same type and rating. A spare fuse can be found in the analyzer Startup Kit.*

#### Fuse Replacement Procedure:

1. Insure that the replacement fuse is: 5x20mm, 500mA, 250V. This fuse can be used for both 115VAC and 230VAC operation.
2. Disconnect the mains power at the source: outlet, switch, circuit breaker, or any other device.
3. Locate the fusible link on the terminal block and gently pull it open. Refer to Section Figure 4.9.
4. The fuse is located inside the fusible link. Open the cover of the link and the fuse will be rejected by the fuse holder clips. Remove the fuse.
5. Insert one end of the new fuse into the clip and push down to secure the fuse in the clip. Close the cover and the fuse will snap into place.
6. Close the fusible link and restore power at the source.

### 8.2.2 Flowcell Cleaning

The colorimeter measuring cell may develop a film from the growth of biological material or from the reagents over time. Cleaning with a concentrated bleach solution should be all that is necessary to remove this material. The Model 3017M has shown to not be susceptible to build-up of this nature for as long as 150-180 days. If the output of the Model 3017M falls outside of the validation checks, then this may indicate the need for measuring cell cleaning. See Section 9, Troubleshooting for a more complete description on this.

**CAUTION**

**Chemical exposure hazard. The chemicals used in this procedure may be hazardous if inappropriately handled or accidentally misused. Protective eyewear is always recommended when contact with chemicals is possible. Follow all precautionary instructions on the labels.**

### Measurement cell cleaning procedure

1. Regular, household bleach, like Clorox®, is all that is necessary for measurement cell cleaning.
2. It is not necessary to remove power from the instrument. Using the keypad, place the instrument in SHUTDOWN mode to prevent rotation of the pumps.
3. Using the syringe assembly that is provided with the analyzer, fill the syringe with 10 ml of full-strength bleach.
4. Remove the plug on the cleaning port and attach the fitting on the end of the tube connected to the syringe assembly.
5. Slowly inject 7-8 mL of the cleaning solution, leaving a small amount in the syringe. The liquid will flow through the measurement cell and into the waste line. Do not remove the syringe assembly.
6. Allow the solution to sit in the measurement cell for 5 minutes.
7. Gently pull the cleaning solution that had been injected in Step 5 back into the syringe. Disconnect the syringe from the tubing at the Luer fitting. Discard the dirty cleaning solution and thoroughly rinse the syringe assembly by pulling 5 full syringe volumes of DI Water and discarding each syringe volume.
8. Fill the syringe with DI Water and gently push the water through the measurement cell. Repeat this step 5 times.
9. Disconnect the cleaning assembly at the flowcell cleaning port, and reinstall the plug.
10. Using the process sample, place the instrument in the **RINSE** mode. Use the UP or DOWN arrows and toggle to the **RINSE** command. Press ► (ENTER). Allow the analyzer to rinse with the process sample for 10 minutes.
11. Toggle to **STARTUP** and press ► (ENTER).

### 8.2.3 Linearization

The 3017M is linearized at the factory and the results verified at the factory before shipment. Under normal circumstances, it should not be necessary to re-linearize the analyzer. **The decision to re-linearize the analyzer should be made in consultation with Technical Support.** There may be other means to solve an apparent issue with the linearization without following this procedure. Some guidance is provide in Section 9, Troubleshooting.

## Linearization Coefficients

There are three linearization coefficients for the 3017M: A-COEF, B-COEF, and C-COEF. These coefficients are stored under the **LINEARIZATION** menu. These coefficients are also recorded at the factory for each 3017M and are stored by the serial number of the analyzer. If you have a question as to the correct value of the coefficients, contact Technical Support and verify them. This may eliminate the need for re-linearization of the analyzer.



The linearization coefficients should not be arbitrarily changed, under any circumstance, as incorrect results will be obtained by the 3017M. If for some reason, the linearization coefficients differ from what is recorded at the factory, the correct value can be entered after consultation with Technical Support.



Record the current linearization coefficients for reference before starting this procedure.

The linearization coefficients are determined by analyzing a series of very well defined standards. Under **LINEARIZATION**, these are designated as: **LOW LINEAR STANDARD**, **MED LINEAR STANDARD**, and **HI LINEAR STANDARD**. The 3017M firmware will determine each of the coefficients after the results of the three standards are recorded.

### 8.2.4 Field Linearization Procedure



Certain settings on the 3017M will be changed during this procedure. It will be necessary to **UNLOCK** the analyzer to modify these settings. Navigate to: **MAINTENACNE < ENGINEERING ACCESS** and enter the passcode, 19.

### Preparation of Linearization Standards

All steps of the Field Linearization process are important and one of the most critical steps is the preparation of the three standards. Reasonable care and good laboratory practices should be followed in the preparation of the standards.

The range of the 3017M is 0 – 5 mg/L. The standards that will be used to linearize the analyzer will need to be within this range. The typical values for linearization standards

are: zero (0), 1.5 – 2.5 mg/L and 4.0 – 5.0 mg/L. Never exceed the maximum range of the analyzer.

All glassware has some chlorine demand; therefore, glassware must be conditioned with chlorine before it is used to prepare standards. Prepare three, 1-L containers by adding 1 ml of household bleach and filling the container to overflowing. Cap the container and allow it sit for a period of several hours. After this conditioning period, thoroughly rinse each container with chlorine-free water that will be used to prepare the standards. DI Water is preferred but not absolutely necessary. Fill each container with the water that will be used to prepare the standards, and determine if there is any chlorine residual. Rinse as many times as necessary.



Very often, DI Water systems are sanitized with sodium hypochlorite (bleach). Therefore, it is possible that these systems may have a low-level residual chlorine level. Make a determination with a handheld meter, or some other technique to verify that the water used in this procedure is chlorine free.

The water that was used to rinse the three containers will be the water used for the zero (0) linearization standard. Prepare the other two standards in the range listed above and verify the concentration with a secondary technique. Allow the standards to sit for 24 hours. Re-verify the concentration and adjust as necessary.



Chlorine concentration can decrease slowly, over time, after the initial preparation. The linearization will be affected if the chlorine standard is slowly decreasing in value while the 3017M is analyzing a standard.

Once the chlorine concentration of the linearization standards have been verified, it will be necessary to enter these values for each of the three linearization standard entries: **LOW LINEAR STANDARD**, **MED LINEAR STANDARD**, and **HI LINEAR STANDARD**.

### Entering the Linearization Standard Values

1. Navigate to **LINEARIZATION**. Use the UP or DOWN arrows and navigate to: **LOW LINEAR STANDARD**. Press ► (ENTER). The default value should be zero (0). Follow the prompts on the screen to enter the correct value. The screen will display the previous menu after entry.
2. Use the DOWN arrow to navigate to: **MED LINEAR STANDARD**. Follow the same procedure as in Step 1.

3. Use the DOWN arrow to navigate to: **HI LINEAR STANDARD**. Follow the same procedure as in Steps 1 and 2. At this point it would be prudent to verify each entry for the three linearization standards.

### Analyzing the Linearization Standards

1. Depending on the location site of the 3017M, it may be necessary to position a table, cart, or some other sturdy and flat surface upon which to rest the linearization standards. Access to the sample inlet fitting on the bottom of the enclosure will be necessary.
2. If the 3017M is running, place it in **SHUTDOWN**. Disconnect the sample line at the bottom of the enclosure and attach a section of 1/8-inch OD, Teflon® tubing. The length of the tubing should not exceed 1 m (3.25-ft). If you do not have this tubing, contact Technical Support and it can be provided for you.
3. Analyze the standards in order of increasing concentration. Place the zero linearization standard, **LOW LINEAR STANDARD** in position. From the keypad, place the 3017M in the **RINSE** mode. Rinse the sample pathway until the sample pathway is free of air bubbles.
4. Once the sample pathway is thoroughly rinsed, press: **STARTUP**. It is not necessary to exit from **RINSE**. The 3017M will move immediately to **STARTUP**.
5. After the **STARTUP** sequence, the 3017M will begin the analysis of the sample. Allow the instrument to make at least five (5) measurements.
6. While the last result is being displayed and before the next measurement, navigate to: **LINEARIZATION < LINEARIZATION TASK < LINEAR TASK LO**. Press the UP button to **LOCK** the last result. This will lock the absorbance value that is associated with this standard.
7. Place the instrument in **SHUTDOWN**. Remove the **LO LINEAR STANDARD** and position the **MED LINEAR STANDARD**. ► (ENTER): **PRIME** and allow the **MED LINEAR STANDARD** to fill the sample path way and insure that all bubbles have been removed from the sample path way. Select: **STARTUP**.
8. While the last result is being displayed and before the next measurement, navigate to: **LINEARIZATION < LINEARIZATION TASK < LINEAR TASK MED**. Press the UP button to **LOCK** the last result. This will lock the absorbance value that is associated with this standard.
9. Place the instrument in **SHUTDOWN**. Remove the **MED LINEAR STANDARD** and position the **HI LINEAR STANDARD**. ► (ENTER): **PRIME** and allow the **HI LINEAR STANDARD** to fill the sample path way and insure that all bubbles have been removed from the sample path way. Select: **STARTUP**.

10. While the last result is being displayed and before the next measurement, navigate to: **LINEARIZATION < LINEARIZATION TASK < LINEAR TASK HI**. Press the UP button to LOCK the last result. This will lock the absorbance value that is associated with this standard.
11. Use the DOWN arrow to select: **RE-LINEARIZE**. Once this selection is made the following screen will be displayed. See below. If the data check passed has passed all criteria, use the UP button to recalculate the linearization coefficients. If the data check did not pass, then it will be necessary to repeat this procedure.

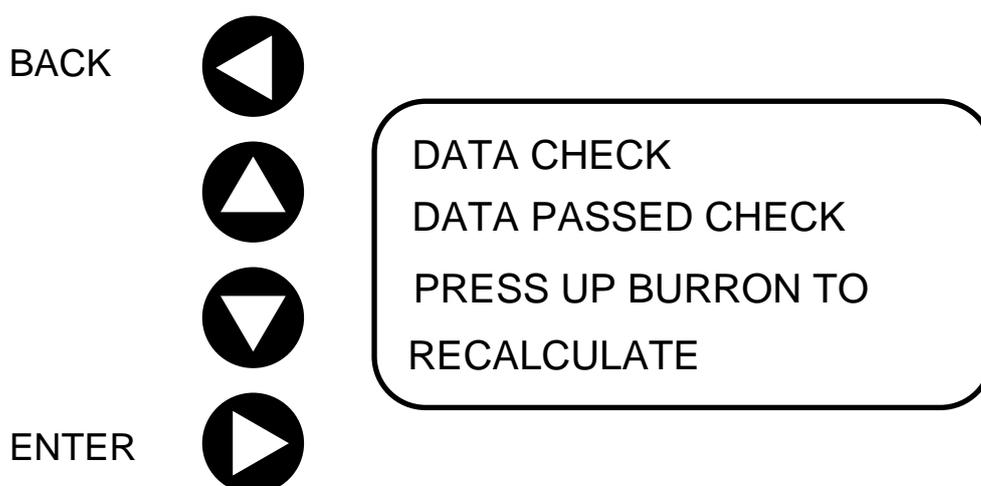

Figure 8.1 3017M Display showing DATA CHECK Screen

12. Place the instrument in **SHUTDOWN**. Remove the **HI LINEAR STANDARD** and position the **MED LINEAR STANDARD**. Enter: **PRIME** and allow the **MED LINEAR STANDARD** to fill the sample path way and insure that all bubbles have been removed from the sample path way. Select: **STARTUP**.
13. The reported value for the **MED LINEAR STANDARD** should be within acceptable variance. If it is not within acceptable variance, it may be necessary to recheck the concentration of the chlorine standards and repeat this process. It would be advisable to contact Technical Support.
14. Upon completion of this procedure, navigate to: **METHOD < METHOD SAVE RESTORE < SAVE CURRENT METHOD**. Failure to take this step will result in the loss of the newly determined coefficients in the event of a power cycle.

## 9 Troubleshooting

### 9.1 Troubleshooting Guide

Table 9.1 provides some basic troubleshooting steps for the analyzer.

Symptom	Cause	Corrective Action
Display does not light, the pumps do not operate and cooling fan is not audible.	No power to the analyzer.	Check the external switch or breaker, connections at the terminal block, insure the fusible link is fully closed, and the fuse is not blown.
Display does not light but the pumps operate and fan is audible.	Loose connection on the control board or issue with the control board.	Check connector from display to main control board. Replace main control board.
Display lights, fan is audible, but the pump, or pumps, do not operate.	Incorrect (low) line voltage.	Measure line voltage at the terminal block.
	Loose connection at the main control board for either pump.	Check connector(s) for affected pump, or pumps.
	Defective power supply	Replace power supply.
	Defective main control board	Replace main control board.
Air bubbles in the line leading to the flowcell.	Sample is not present at the sample pick-up line.	View the clear tubing on the Sample Inlet Device (if installed). Liquid should be visible.
		Check for the presence of sample in any other device or sample point.
		Check for clogged tubing or screen.
	Reagents are empty.	Replace reagents.
	Reagent pump platens are not properly tensioned.	Tension the pump platens by three "clicks" from the released position. Refer to Section 5 of the manual.
	Sample or reagent tubes are worn or damaged.	Check sample and reagent tubes for wear and replace, if necessary.
	Loose fittings	Check that all fittings are tight.
Sample and reagent tubes were not properly primed after service.	Select PRIME from the Main Menu and fill lines with sample and reagents.	

Symptom	Cause	Corrective Action
Zero Reading	Bubbles in the flowcell.	See above.
	Sample is flowing but reagents are not flowing.	Check reagent levels.
		Disconnect buffer, and/or, indicator tube at flowcell. Reagent should drip each tube. If not present, see below.
		Check tension on reagent pump platens.
	No chlorine in sample.	Verify that sample has chlorine with grab sample measurement.
Reagents are flowing but sample is not flowing.	Disconnect the sample line at the outlet of the sample pump. Sample should drip from the tubing. Reconnect and check for flow at the outlet of the measurement cell. If no flow is present, the flowcell is clogged.	
Low Reading	Clogged sample tubing or screen (if installed).	Replace tubing.
	Worn pump or reagent pump tubes.	Replace tubing.
	Weak or improperly prepared reagents.	Replace reagents.
	Dirty flowcell	Clean flowcell.
Erratic Reading	Air bubbles in the optical cell.	Use all of the recommended tips in the <b>Air bubbles in the line leading to the flowcell</b> symptom above.
Negative Drift	Weak reagents.	Replace reagents.
Positive Drift	Dirty optical cell	Clean optical cell

Table 9.1 basic troubleshooting steps

## 9.2 Using the Manual Controls and STATUS Screen for Troubleshooting

In Section 6, the User Interface and all of the Tiers in the firmware were described in detail. The various functions and status screens that are available to the User can be very helpful for troubleshooting purposes. The items below list some of the more common uses.

### 9.2.1 No Sample or Reagent Flow

#### RINSE Function

If the instrument is running, place it in **SHUTDOWN**: Press ► (ENTER) < **SHUTDOWN**. Use the UP and DOWN arrows and navigate to **RINSE**. Press ► (ENTER). The Sample

Pump will rotate and attempt to pull sample from the process connection, or any container that is connected to the sample line.

Observe the line from the sample point; it should be filled with liquid. If it is filled with liquid, follow the flow path and disconnect at various points to determine where flow is lost. If the line is not filled with liquid, or if it is partially filled, and the liquid moves, back and forth, but does not advance up the tube, the Sample Pump tube should be replaced.

**PRIME Function**

If the instrument is running, place it in **SHUTDOWN**: Press ► (ENTER)< **SHUTDOWN**. Use the UP and DOWN arrows and navigate to **PRIME**. Press ► (ENTER). The Sample Pump and Reagent Pump will rotate and attempt to pull sample from the process connection, or any container that is connected to the sample line, as well as, reagents from the reagent containers. If the sample has chlorine, the liquid from the exit of the measurement cell should be pink in color. This may be difficult to discern for low chlorine concentration.

If sample flow has been established and confirmed, using the previous step, disconnect the Buffer and Indicator tubes at the Flowcell. Buffer and Indicator solution should be visible at each of these connections. If no liquid is visible, check the container for reagent level and clogging of the reagent bottle dip tube. Check the tension on the Reagent Pump tensioners, but do not exceed the recommended tension. Refer to Section 4. If the reagent level is sufficient, the dip tube is free of obstruction, and not flow is present, replace the Reagent Pump tubes. Always replace them as a set.

**9.3 Using Tier 3 Selections Under STATUS for Troubleshooting**

The **STATUS** menu in Tier 3 has various selections that can be used for troubleshooting purposes. The settings in each of these entries are nonadjustable. A complete listing and description of the items in this Tier is listed in Table 9.2. A brief explanation is given on how each item could be helpful in troubleshooting.

<b>Tier 3</b>	Under STATUS – For Troubleshooting (No adjustments)
Option	Description
Refrnc VDC	The instantaneous voltage seen at the A/D convertor from the Reference Channel.
Sample VDC	The instantaneous voltage seen at the A/D convertor from the Sample Channel.
Ref	The Gain Setting for the Reference Channel. (1) is the lowest setting and (8) is the highest setting. The number to the right of the Gain Setting can

Tier 3	Under STATUS – For Troubleshooting (No adjustments)
Option	Description
	be used to monitor the Gain change.
Sam	The Gain Setting for the Sample Channel. (1) is the lowest setting and (8) is the highest setting. The number to the right of the Gain Setting and can be used to monitor the Gain change.
L	The low linearization sample and its absorbance.
H	The high linearization sample and its absorbance
M	The medium linearization sample and its absorbance
C	The calibration sample and its absorbance
Liquid Lvl Sensor	The liquid level sensor status: 1 is tripped, 0 is not tripped
Error	The error status: 1 is showing an error flag, 0 is not showing an error flag
Firmware	The two-letter code is the firmware revision, ex. DZ.
PCA	The PCA revision level.
Compiled	The compile date of the firmware.

Table 9.2 Tier 3 selections under the STATUS menu. These are nonadjustable settings and used as references for troubleshooting purposes

### 9.3.1 Main STATUS screen

An example of the Main **STATUS** screen is shown in Figure 9.1. The values in this figure are representative of the values that will be found on a 3017M; however, the exact values will be different for every instrument. This screen displays the following values from Table 9.2: **Reference VCD**, **Sample VCD**, **Ref (Reference Gain)**, and **Sam (Sample Gain)**.

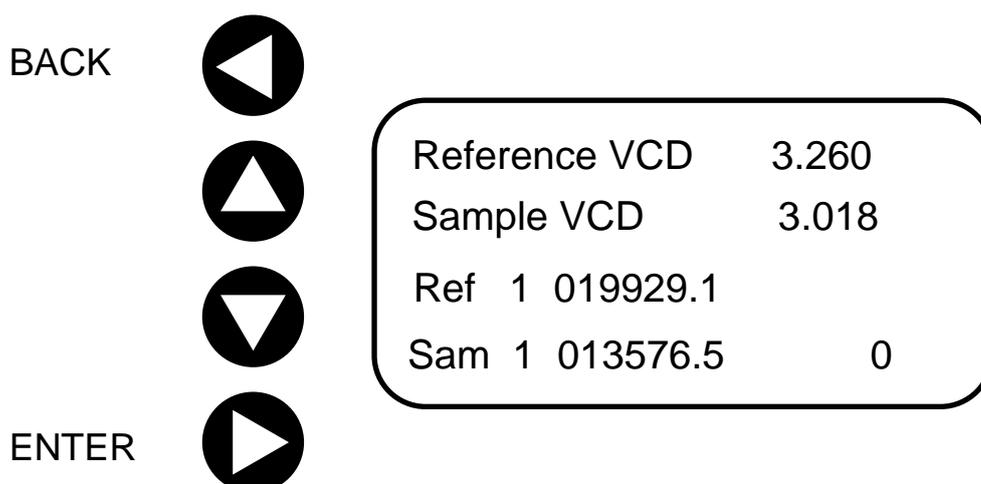

Figure 9.1 An example of the Main STATUS screen

## Reference VDC

As explained in Table 9.2, the Reference VDC is the instantaneous voltage at the A/D converter for the reference channel. This voltage is typically in the range of 2.50 V to 3.50 V. The voltage reading on the reference channel is not affected by sample flowing through the flowcell; however, the voltage on the reference channel should be comparable to the voltage on the Sample channel when clean, reagent-free water is flowing through the flowcell, but the voltages will not be identical. Instability on the reference channel can only be caused by some issue with the LED, Reference photodiode, or the light guide that transmits light from the LED to the photodiode. If this voltage is outside of these values, the results could be affected, and you should contact Technical Support. A voltage of 0.5 V, or lower, indicates that the LED or photodiode is not working.

## Sample VDC

As explained in Table 9.1, the Sample VDC is the instantaneous voltage at the A/D converter for the sample channel. This voltage is nominally in the range of 2.50 V to 3.50 V. The voltage reading on the sample channel is affected by the intensity of the color change from the reaction of DPD with the chlorine in the sample flowing through the flowcell. As the intensity of the color changes, the voltage will decrease. At the INTEGRATION step in the instrument cycle, the voltage output should be very stable. The sample voltage may go lower than 2.50 V, if the chlorine concentration in the sample is at, or above, the maximum range of the analyzer. If this voltage is outside of these values, the results could be affected, and you should contact Technical Support. A voltage of 0.5 V, or lower, indicates that the LED or photodiode is not working.

## Ref (Reference Gain)

The electronics and control firmware of the 3017M is constantly monitoring, and adjusting, if necessary, the Gain setting on both the Reference and Sample channels. The number after "Ref" is the Gain setting. For the reference channel, this number is typically 1, or possibly 2. The number to the right of the Gain setting is the actual Analog-to-Digital converter (A/D) counts for the reference channel. This number should be between 32K and 15K counts. If for some reason, the output of the A/D cannot reach 15K counts, the Gain setting will be increased to the next highest setting. The only factors that will affect the Reference Gain setting is the LED output, the condition of the fiber optic pathway between the LED and the photodiode, the photodiode, and temperature. A LED will become more efficient at lower temperatures; therefore, a change in the Reference counts,

and possibly, the Gain setting could be observed at low temperatures. Conversely, a LED becomes less efficient at high temperature.

### Sam (Sample Gain)

The electronics and control firmware of the 3017M is constantly monitoring, and adjusting, if necessary, the Gain setting on both the Reference and Sample channels. The number after “Sam” is the Gain setting. For the sample channel, this number is typically 1, or possibly 2, but it could go as high as eight (8). The number to the right of the Gain setting is the actual Analog-to-Digital converter (A/D) counts for the reference channel. This number should be between 32K and 15K counts. If for some reason, the output of the A/D cannot reach 15K counts, the Gain setting will be increased to the next highest setting. The same factors that can affect the Reference channel; LED output, the condition of the fiber optic pathway between the LED and the photodiode, the photodiode, and temperature can affect the Sample channel. A LED will become more efficient at lower temperatures; therefore, a change in the Sample counts, and possibly, the Gain setting could be observed at low temperatures. Conversely, a LED becomes less efficient at high temperature. If the Reference Gain setting reaches a value of eight (8), it would be advisable to contact Technical Support.

The output and Gain setting of the Sample channel is also greatly affected by the condition of the measurement cell. It can be expected that the measurement cell will become dirty over time from possible biological growth on the walls of the cell, or staining from the DPD reaction products. In the normal course of operation, it can be expected that the Gain setting will increase over time. If the Gain setting reaches a value of eight (8), then some maintenance action would be necessary. In most cases, this would be cleaning of the measurement cell. If cell cleaning does not result in a lower Sample Gain setting, it would be advisable to contact Technical Support.

### Countdown Timer

In Section 5, Analyzer Startup, the **STARTUP** sequence was explained and the steps in that sequence defined. As part of the STARTUP sequence, there is a step, **AUTOGAIN SET**. At this point in the **STARTUP** sequence, sample that is free of reagent is flowing through the measurement cell. The A/D counts for both Reference and Sample are being monitored, and if a Gain change is necessary, it is made during this time.

A change in the Gain does not result in an immediate change in the output. Therefore, a **COUNTDOWN TIMER** is initiated. This is the number zero (0) in the lower-right-hand corner of the **STATUS** screen. The Gain change is made, and the slowly starts to rise,

while the timer counts down from 10. If at the end of ten seconds, the value of the Reference and Sample output has not reached the 15K minimum criteria, the counter resets, and the countdown starts over. Once the minimum value, or some number above the minimum value, is reached the counter will stop. If the timer appears to be stuck in an endless loop, it would be advisable to contact Technical Support.

## 9.3.2 Liquid Level Sensor and Error Levels

### Liquid Level Sensor

A liquid level sensor is not used on the 3017M. Therefore, it can be disregarded.

### ERR 1-4 (Error Levels and MODBUS register)

The 3017M has four levels of Errors and a MODBUS register assigned to that error. The WARNINGS and ERRORS that will be displayed on the HOME screen are listed in Table 9.3. The four levels of Errors are described as follows:

#### ERR 1

This is a fatal error. This error is usually the result of a processor failure, or the failure of some other critical electrical component. A failure of this type will prevent the operation of the instrument. Call Technical Support.

#### ERR 2

This is an error that may immediately affect the analyzer results. The analyzer will operate; however, it would be advisable to contact Technical Support in some cases. Refer to Table 9.2.

#### ERR 3

This is an error that may not immediately affect the analyzer results; however, if left unattended, the analyzer results will ultimately be affected.

#### ERR 4

These are WARNINGS. WARNINGS will self-reset once the condition causing the WARNING clears.

Warning or Error	Level	Cause	Corrective Action
ERROR: ADC	1	An A/D failure.	Call Technical Support.
ERROR: FLASH/ADDRESS	1	A Processor failure.	Call Technical Support
ERROR: MATH OR FLOAT	1	A Processor failure.	Call Technical Support
ERROR: SELF TEST	2	System did not pass Self-Test.	Call Technical Support
ERROR: DATA OVERRANGE	2	A continuous bad data reading. Either a bad A/D reading or bad linearization/gain settings.	Navigate to MAINTENANCE < METHOD SAVE RESTORE. Select: SAVE CURRENT METHOD < ENTER Navigate to STATUS. Insure that the values are in the range as described in Section 9.3.1. If the values are not in the proper range, navigate back to <b>METHOD SAVE RESTORE</b> and select: <b>DEFAULT METHOD 3017</b> . If the values are in the proper range, it will be necessary to contact Technical Support to obtain the correct linearization coefficients.
WARNING: REAGENTS OLD	2	The reagents have been in service more than seven (7) days past the <b>REAGENT LIFETIME</b> setting.	Replace the reagents. Navigate to <b>CLEAR ALARMS AND TIMERS</b> under <b>MAINTENANCE</b> and clear the error. A new timer for <b>REAGENT LIFETIME</b> will be set.
ERROR: AUTOGAIN	3	The instrument was unable to correct itself using Autogain. It usually means that the cell needs to be cleaned, or the cell is broken or there is a bubble in the cell.	Inspect the flow path from the sample tap to the flowcell for the presence of bubbles. If bubbles are present, correct the cause. If bubbles are not present, follow the cleaning procedure in Section 8. If cleaning does not correct the issue, remove the Optical Cell exit fitting and extract the Flowcell glass. See Section 0. If the Flow cell glass is broken, replace it.
ERROR: CALIBRATION	3	The instrument could not generate a good calibration. This could happen during field calibration if the standard is not the proper concentration or the Flowcell is compromised.	Insure that a value for the Calibration Standard has been entered under: <b>LINEARIZATION &lt; Calibration Standard</b> . If a value of zero (0) is entered for the Calibration Standard, this will also cause the error. Refer to the corrective action under <b>ERROR AUTOGAIN</b> and follow these steps if necessary.

Warning or Error	Level	Cause	Corrective Action
ERROR: LINEARIZATION	3	The instrument could not generate a good Linearization. Either the standards were analyzed in the incorrect order, or the Flowcell is compromised.	Repeat the process and insure that the standards are the proper value and are analyzed in the proper order. Refer to the corrective action <b>under ERROR: AUTOGAIN</b> and follow these steps if necessary.
ERROR: TEMPERATURE	3	The temperature has been out-of-range for over 24 hours.	If the analyzer is installed in a location in which the ambient temperature exceeds the 3107M specifications, this could cause the error. If ambient conditions are within specification, the Thermoelectric Cooler assembly will need to be checked for proper operation. Insure that external cooling fan is ON and turning, place your hand on the cold finger (metal plate against the Indicator bottle) and determine if it is cold. It should be cold to the touch. If the cold finger is not cold, the TEC assembly will need to be serviced.
WARNING: TEMPERATURE	4	Temperature is out of range.	See the Corrective Action for ERROR: TEMPERATURE
WARNING: REAGENTS OLD	4	The reagents are within seven (7) days of the <b>REAGENT LIFETIME SETTING</b> .	Change the reagents within seven (7) days or an ERROR will be displayed at the end of seven (7) days.

Table 9.3 List of ERRORS and WARNINGS on the 3017M

### 9.3.3 Firmware and PCA Revision Levels

The information on this screen is for reference only. It may be necessary to have this information available to Technical Support for assistance with troubleshooting.

## 10 Parts and Accessories

The parts and accessories for the Model 3017M Chlorine Analyzer are listed on the following Illustrated Parts Breakdowns.

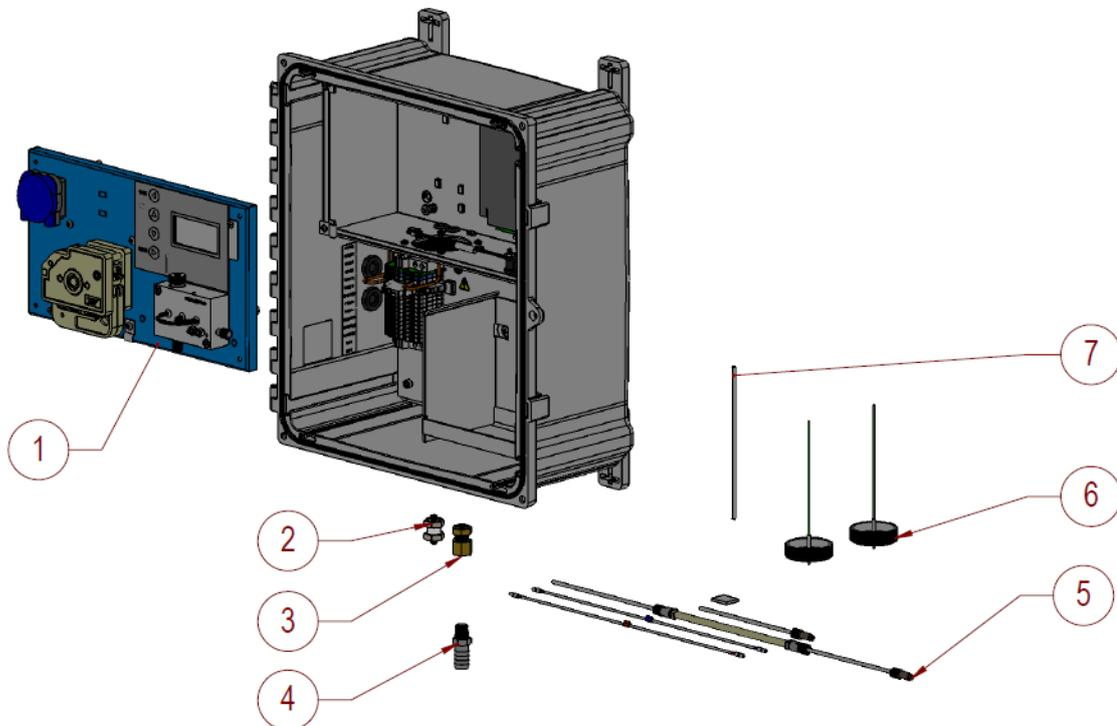

ITEM #	DESCRIPTION
1	ANALYTICAL PLATE-3017M
2	FTNG-BR/Ni 1/8" X 1/8" PUSHLOK BLKHD
3	FTNG-BR/Ni 1/8" PUSHLOK TO 1/4"FMNPT
4	FTNG-NY 1/2 HS TO 1/4 MNPT BLACK
5	KIT - 3017M SPARE TUBING
6	KIT-9017/3017M REAGENT CAPS
7	TUBING-PTFE 1/8 X .062" ID CLEAR



ITEM #	DESCRIPTION
1	COVER-9017/3017 SAMPLE PUMP



ITEM #	DESCRIPTION
1	ROLLERS - 9017/3017 SAMPLE PUMP



ITEM #	DESCRIPTION
1	PLATEN-9017/3017M PUMP, ADJUST. LEVER

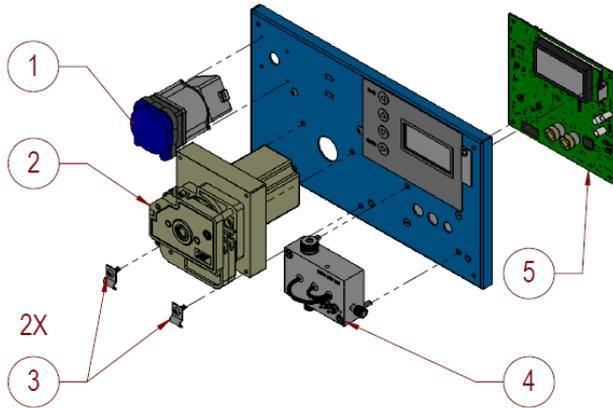

ITEM #	DESCRIPTION
1	PUMP-9017 SAMPLE
2	PUMP-DRIVE ASSY 9017 REAGENT
3	CLAMP-HALF P-CLIP .250 STEEL
4	ASSY-3017M OPTICAL CELL/MANIFOLD
5	PCF-9017 TRO MAIN CONTROL

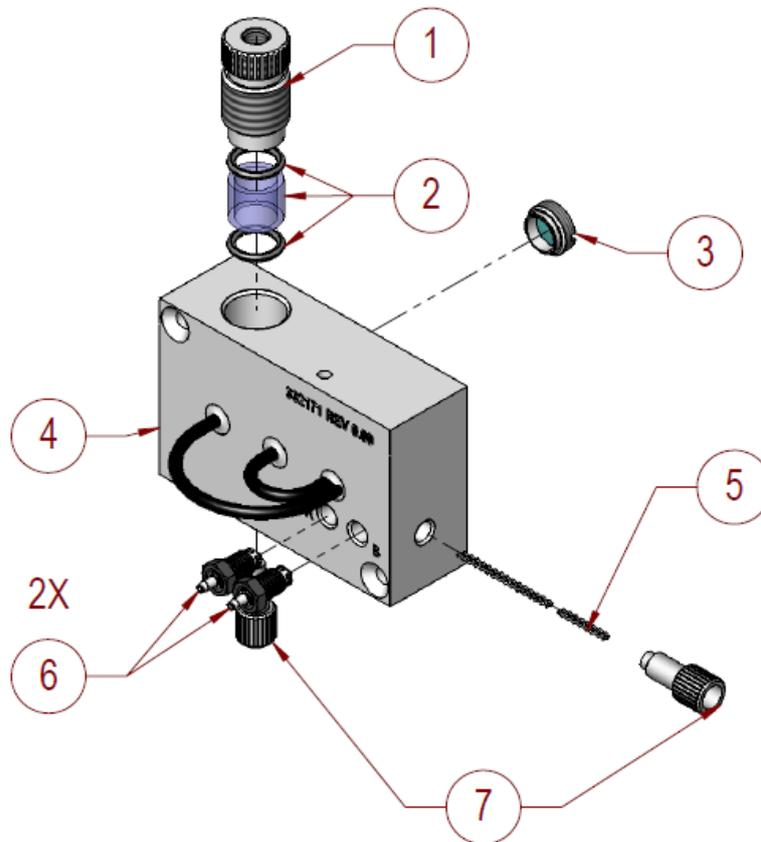

ITEM #	DESCRIPTION
1	FTNG-3017 OPTICAL CELL EXIT
2	KIT-3017M FLOWCELL GLASS AND ORING
3	ASSY-LENS 3017M SAMPLE FLOW CELL
4	ASSY-3017M CELL W/POTTED LIGHT GUIDES
5	MIXER-3017M OPTICAL CELL (PAIR)
6	ASSY- FITTING 3017M REAGENT JET .005"
7	PLUG-1/4-28 TEFZEL

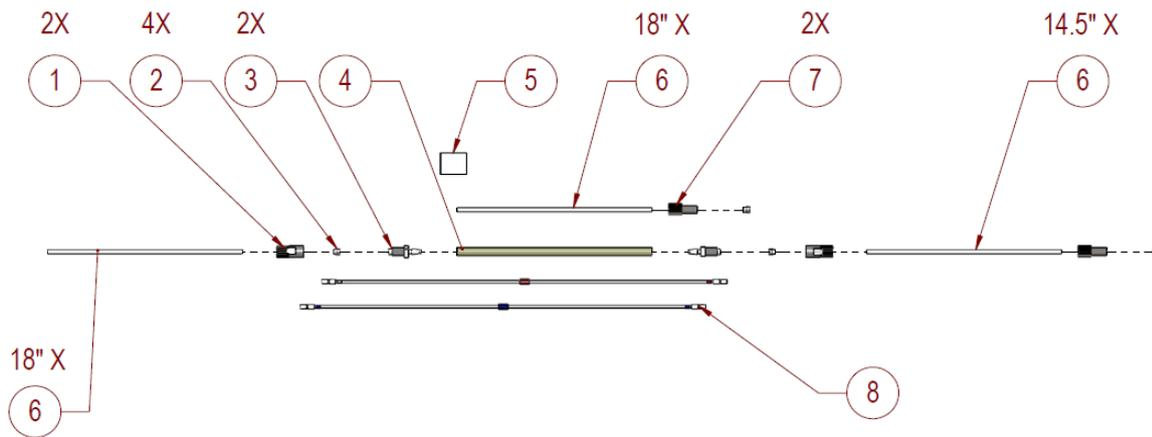

ITEM #	DESCRIPTION
1	FTNG-NUT CPVC 1/4-28 X 1/8" RV
2	FRLE-TFZL 1/8 FLANGELESS
3	FTNG-ADPTR 1/4-28 X 3/16" ID BARB
4	TUBE-3017M SAMPLE PUMP 3/16" ID
5	LUBE-SILICONE 9017 PUMP TUBING 2GM
6	TUBING-PTFE 1/8 X .062" ID CLEAR
7	FTNG-NUT PK 1/4-28 1/8 NAT FLS
8	KIT-3017M REAGENT TUBES

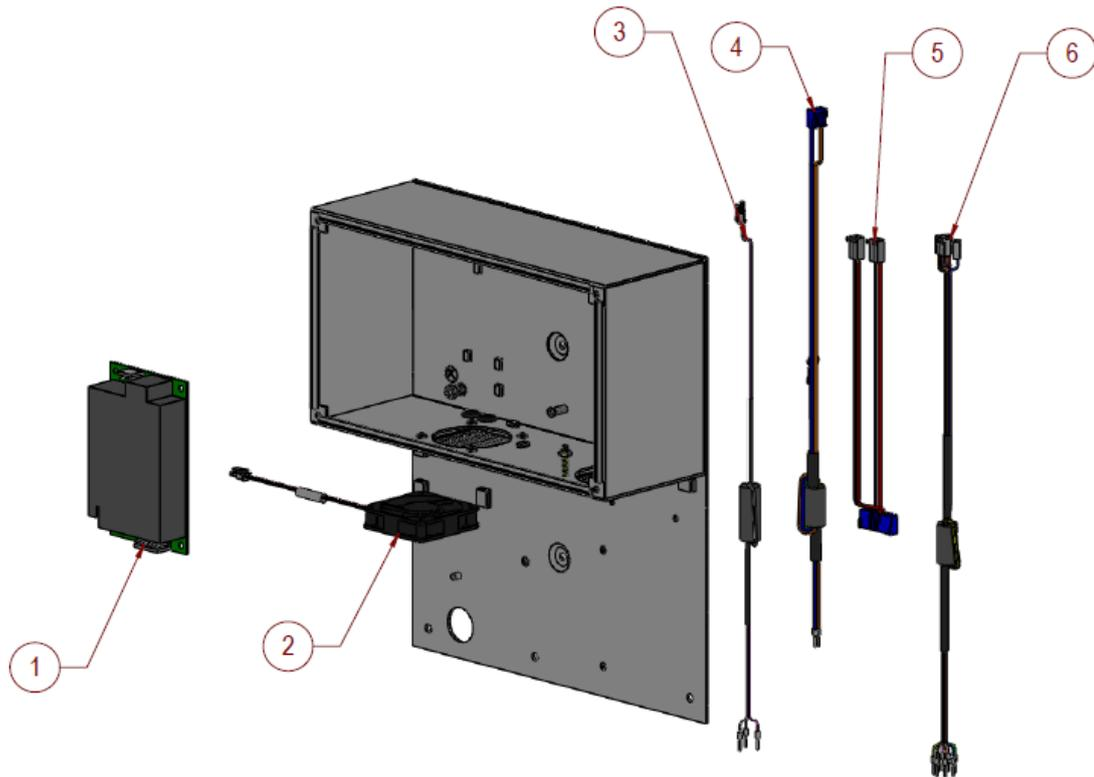

ITEM #	DESCRIPTION
1	POWER SUPPLY-160W 24VDC 3X5
2	ASSY-9017 INTERNAL FAN
3	CABLE-9017 RS485 W/FERRITE, R3
4	CABLE HARNESS-9017 AC PWR/SWITCH W/FERRITE
5	CABLE-9017 DC FROM PWR SPLY TO MAIN PCA
6	CABLE-9017M I/O PCF TO DIN

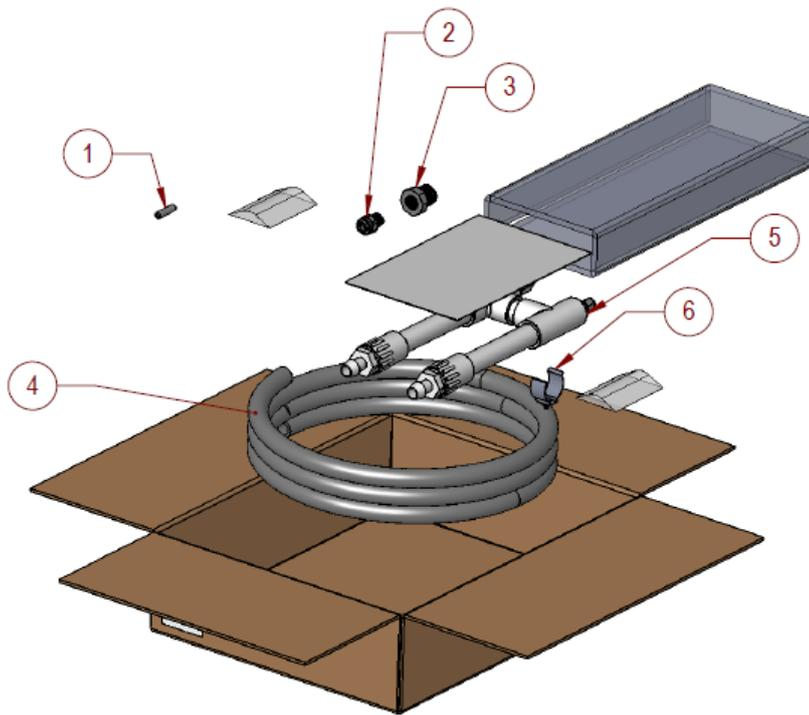

ITEM #	DESCRIPTION
1	FILTER-PE 60U
2	FTNG-PUSHLOK ACTL 1/4NPT X 1/4"
3	FTNG-PVC 1/2" MNPT X 1/4" FNPT
4	TUBING-PVC CLR 1/2" ID X 3/4" OD
5	ASSY-SAMPLE INLET SYSTEM 9210
6	CLIP-COMPONENT 1"

## 11 MODBUS

### 11.1 0xxxx's Coils(Read/Write)

No.	Hex	Type	Name	Description
1	0x01	Bit	Unused	Unused
2	0x02	Bit	RS485Enabled	Enable use of ModBus RS485
3	0x03	Bit	4-20Enabled	Enable Use of 4-20 mA Output
4	0x04	Bit	ClearAlarms	Clear all alarms, coil automatically reset
5	0x05	Bit	ClearAlarmsAndTimers	Clear all alarms and hour/day/month timers, coil automatically reset
6	0x06	Bit	ZeroReading	Clear all math and await next reading
7	0x07	Bit	ZeroNewResultFlag	Clear New Result (status 6)
8	0x08	Bit	UseAutoGain	If Set, over-range AD readings will AutoGain
9	0x09	Bit	UseCcoef	force cal curve thru 0 cleared
10	0x0A	Bit	Relay1	Activate/Clear Relay 1
11	0x0B	Bit	Relay2	Activate/Clear Relay 2
12	0x0C	Bit	UseAutoLEDSet	AutoSet LEDs on Auto-Gain Fail
13	0x0D	Bit	TemperatureDisable	Turn off control and alarms (To be used when Cooler not installed)
14	0x0E	Bit	Abort	Force Timer to Zero

### 11.2 1xxxx's Status Inputs(Read Only)

No.	Hex	Type	Name	Description
1	0x01	Bit	Error	
2	0x02	Bit	Spare	
3	0x03	Bit	Relay1Active	
4	0x04	Bit	Relay2Active	
5	0x05	Bit	StandbymodeFlag	
6	0x06	Bit	NewResult	
7	0x07	Bit	IsInAutoGain	
8	0x08	Bit	StartHit	
9	0x09	Bit	StopHit	
10	0x0A	Bit	Fault	
11	0x0B	Bit	LiquidLevelLow	
12	0x0C	Bit	IsInAutoLed	

### 11.3 3xxxx's Input Registers(Read Only)

No.	Hex	Type	Name	Description
1,2	0x01	Float	currentClppm;	current chlorine value in ppm (3 dec places)
3,4	0x03	Float	currentInteg;	current integrated value in area counts
5	0x05	Unsigned Int	SecsSinceSample;	Time in seconds since last reading
6	0x06	Unsigned Int	firmrvsnTRO;	Firmware Revision in 2 characters "xx"
7	0x07	Unsigned Int	unused06;	Spare
8	0x08	Unsigned Int	unused07;	Spare
9	0x09	Unsigned Int	Modelnumber;	Product number 9017
10	0x0a	Unsigned Int	ReadingStatus;	0-unknown 1-normal 2-OverRange 3-UnderRange 4-need standard 5-need sample 6-error 7-old reading
11	0x0b	Unsigned Int	PCA_rev;	PCA REV in 2 characters "xx"
12	0x0c	Unsigned Int	Instrument Error Summary: (bitmapped) ErrorExists Alarm1Active Alarm2Active Spare	0 Error 1 Alarm 1 is active 2 deactivated 3-15
13,14	0x0d	Long Int	Level4Error Spare LiqLvlSensErr ReadingError  ReagentOld  TempError Spare LockedOut  Spare	Instrument warning, readings OK 0-1 2 Liquid Level Sensor 3 Reading error (Err Single A/D reading) 4 Reagent is old and needs to be replaced (REPL) 5 Temp error 6-14 15 The Unit is Locked Out For Maint (No Modbus Writes Allowed) 16-31
15,16	0x0f	Long Int	Level3Error	Instrument error, readings questionable

No.	Hex	Type	Name	Description
			CalError LinError AutoZeroFail  Spare TempError  Spare	0 Calibration error (ZCAL) 1 Linearization error (ZCAL) 2 Failure to Autozero correctly, may be due to bubbles in cell, dirty cell, old reagents, or damage.  3-8 9 Temperature error, will contribute to decreased reagent lifetime 10-31
17,18	0x11	Long Int	Level2Error  PostError ContinuedDataError  ReagentOld  Spare	Instrument Failure, requires intervention  0 POST error (POST) 1 Multiple Data Errors-results are questionable 2 Reagent older than ReagentMonthTimer 3-31
19,20	0x13	Long Int	Level1Error Spare A/D error FlashReadErr FlashWritErr AddError MathError StackOvfl Spare	Instrument failure, take offline 0 spare 1 A/D Continued Failure 2 Continued flash data read 3 Continued flash data write 4 Addressing error Firmware 5 Math Error Firmware 6 S/W stack overflow 7-31
21-31		int	spare	
32	0x1f	unsigned int	ReagMonthTimer	a timer to determine how old the reagent is

## 11.4 4xxxx's Input Registers(Read/Write)

No.	Hex	Type	Name	Description
1	0x01	Unsigned Int	User	User Defined Register (Requested by Customer)
2	0x02	Unsigned Int	Units	0=ppm, 1=mg/l
3	0x03	Unsigned Int	Language	0=Engl, 1=Spanish, 2=French, 3=German, 4=Italian
4	0x04	Unsigned Int	Method	0=TRO, 1=Municipal
5,6	0x05	Float	clppm420Lo	Chlorine lo equiv to 4mA ppm*1000
7,8	0x07	Float	clppm420Hi	Chlorine Hi equiv to 20mA ppm*1000
9	0x09	Unsigned Int	error420output	0-Off, 1-0mA, 2-2mA, 3-4mA
10	0x0a	Unsigned Int	BaudRate	RS-485 Baud Rate
11	0x0b	Unsigned Int	PowerUpMode	0=shutdown, 1=standby, 2=startup
12	0x0c	Unsigned Int	LinearizationMode	0=TRO 2point cal 1=Muni, 3-Point Polynomial
13	0x0d	Unsigned Int	DaysTillReagentAlarm	Default 30 days, 90 for cooler option
14	0x0e	Unsigned Int	ModBUSAdd	ModBUS Address
15	0x0f	Unsigned Int	RTUorASCII	ModBUS Protocol 0=RTU, 1=ASCII
16	0x10	Unsigned Int	Relay1Type	0-Off, 1-Low alarm, 2-High alarm, 3-Error alarm
17,18	0x11	Float	Relay1SetPoint	
19	0x13	Unsigned Int	Relay2Type	0-Off, 1-Low alarm, 2-High alarm, 3-Error alarm
20,21	0x14	Float	Relay2SetPoint	
22	0x16	Unsigned Int	unimplemented	
23	0x17	Unsigned Int	TimeStbyWait	Seconds between pump pulse in Standby mode
24	0x18	Unsigned Int	TimeRunTotal	Time - Total Cycle Time in seconds
25	0x19	Unsigned Int	TimeStbyWaitOld	no longer in use
26	0x1a	Unsigned Int	TimeInjStart	Time in Seconds from 0 for injection starts
27	0x1b	Unsigned Int	TimeInjStop	Time in Seconds from 0 for injection stop
28	0x1c	Unsigned Int	TimeIntegStrt	Time in Seconds from 0 for integration start
29	0x1d	Unsigned Int	TimeIntegStop	Time in Seconds from 0 for integration stop
30	0x1e	Unsigned Int	TimeStbyRun	Time in Seconds for pumps to run in Stby
31	0x1f	Unsigned Int	TimeRinse	Time in Seconds for rinse
32	0x20	Unsigned Int	TimeIntegBase	Time in Seconds from 0 to freeze baseline

No.	Hex	Type	Name	Description
33	0x21	Unsigned Int	TimeRelay1on	Time in Seconds from 0 turn relay 1 on
34	0x22	Unsigned Int	TimeRelay1off	Time in Seconds from 0 turn relay 1 off
35	0x23	Unsigned Int	TimeRelay2on	Time in Seconds from 0 turn relay 2 on
36	0x24	Unsigned Int	TimeRelay2off	Time in Seconds from 0 turn relay 2 off
37	0x25	Unsigned Int	SmplFlowRun	Sample Flow Rate During Run
38	0x26	Unsigned Int	SmplFlowPrime	Sample Flow Rate During Prime
39	0x27	Unsigned Int	SmplFlowStby	Sample Flow Rate During Standby
40	0x28	Unsigned Int	SmplFlowRinse	Sample Flow Rate During Rinse
41	0x29	Unsigned Int	ReagFlowRun	Reagent Flow Rate During Run
42	0x2a	Unsigned Int	ReagFlowPrime	Reagent Flow Rate During Prime
43	0x2b	Unsigned Int	ReagFlowStby	Reagent Flow Rate During Standby
44	0x2c	Unsigned Int	ReagFlowRinse	Reagent Flow Rate During Rinse
45	0x2d	Unsigned Int	RunMode	shutdown=0, standby=01, startup=02, prime=03, run=04, calib=05, rinse=06
46	0x2e	Unsigned Int	ForceToMenuTreeS tate	(Used for Troubleshooting)
47	0x2f	Unsigned Int	MemOps	Memory Operations
48	0x30	Unsigned Int	CurrentTempAct	The current actual temperature
49	0x31	Unsigned Int	CurrentTempSet	The current temperature setpoint
50	0x32	Unsigned Int	TempSetPointRun	Temperature SetPoints
51	0x33	Unsigned Int	TempSetPointStby	Temperature SetPoints
53,54	0x34	Float	currentSamAD	current sample reading
55,56	0x36	Float	currentRefAD	current reference reading
57	0x38	Unsigned Int	current4to20	current 4-20 ma output value
58	0x39	Unsigned Int	Standard4mA	D/A Calib counts=Value For Outputting 4 mA
59	0x3a	Unsigned Int	Standard20mA	D/A Calib counts= 20 mA
60	0x3b	Unsigned Int	LEDGrn	Green Led Preset 1-100 (=0-65535)
61	0x3c	Unsigned Int	LEDBlu	Blue Led Preset 1-100 (=0-65535)
62	0x3d	Unsigned Int	LEDRed	Red Led Preset 1-100 (=0-65535)
63	0x3e	Unsigned Int	GainCh0	Gain 0=1 1=2 2=4 3=8 4=16 5=32 6=64 7=128
64	0x3f	Unsigned Int	GainCh1	Gain 0=1, 1=2, 2=4, 3=8 ,4=16, 5=32, 6=64, 7=128
65	0x40	Unsigned Int	LinLowConc	The lo linearization standard; ppm*1000
66	0x41	Unsigned Int	LinMedConc	The med linearization standard; ppm*1000

No.	Hex	Type	Name	Description
67	0x42	Unsigned Int	LinHiConc	The hi linearization standard; ppm*1000
68,69	0x43-4	Float	CalibrateGain	the gain factor to snap the line
70,71	0x45-6	Float	LinearizeAcoef	a-factor in $y=ax^2+bx+c$
72,73	0x47-8	Float	LinearizeBcoef	b-factor in $y=ax^2+bx+c$
74,75	0x49-a	Float	LinearizeCcoef	c-factor in $y=ax^2+bx+c$
76,77	0x4b-c	Float	LinearizeLowAbsorb	locked cal absorbance for lo standard
78,79	0x4d-e	Float	LinearizeMedAbsorb	locked cal absorbance for med standard
80,81	0x4f-0	Float	LinearizeHiAbsorb	locked cal absorbance for hi standard
82	0x51	Unsigned Int	CalibCommand;	01=lock low, 02=lock med, 03=lock hi, 04=recalculate
83	0x52	Unsigned Int	CalibrateStd;	The calibration standard; ppm*1000
84	0x53	Unsigned Int	Relays	(bitmapped) mpc_out_ISO_Start 0; mpc_out_ISO_Stop 1; mpc_out_Relay_2 2; mpc_out_Relay_1 3; mpc_out_Spare 4; mpc_out_Spare 5; mpc_out_Fault 6; mpc_out_Spare 7-f
85	0x54	Unsigned Int	Level4ErrMaskU;	Error Mask, 1=error bit enabled 10- 1f
86	0x55	Unsigned Int	Level4ErrMaskL;	Error Mask, 1=error bit enabled 0-f
87	0x56	Unsigned Int	Level3ErrMaskU;	Error Mask, 1=error bit enabled 10- 1f
88	0x57	Unsigned Int	Level3ErrMaskL;	Error Mask, 1=error bit enabled 0-f
89	0x58	Unsigned Int	Level2ErrMaskU;	Error Mask, 1=error bit enabled 10- 1f
90	0x59	Unsigned Int	Level2ErrMaskL;	Error Mask, 1=error bit enabled 0-f
91	0x5a	Unsigned Int	Level1ErrMaskU;	Error Mask, 1=error bit enabled 10- 1f
92	0x5b	Unsigned Int	Level1ErrMaskL;	Error Mask, 1=error bit enabled 0-f

## 11.5 Instrument Error Summary

Detailed description of Modbus Register 12, Instrument Error Summary

This register is for information only. It provides a quick glance at the error status registers without reading additional registers. It is bitmapped and in an unsigned integer.

No.	Hex	Type	Name	Description
12	0x0c	Unsigned Int	Instrument Error Summary: (bitmapped) ErrorExists Alarm1Active Alarm2Active Spare	0 Error 1 Alarm 1 is active 2 deactivated 3-15

Following is a description of the bits, the causing condition, and steps to clear the error if possible:

BIT POSITION	ERROR DESCRIPTION	CAUSING EVENT	CLEARING ACTIONS
0	ERROR EXISTS	An Enabled error from LEVEL4, LEVEL3, LEVEL2, or LEVEL1 exists. This is for information only and if set, the user should check the ERROR-LEVEL registers in order to ascertain what actions (if any) are necessary.	This bit is automatically cleared when all other errors are cleared.
1	Relay 1 Active	This is a user defined Alarm. It's action is defined by Relay1Type: 0-Off, 1-Below Setpoint, 2-Above Setpoint, 3-Error alarm. If the Relay1Mode is set to type 1 then if the CI level falls below Relay1SetPoint then Relay1 is set and this bit is set.  If the Relay1Mode is set to type 2 then if the CI level rises above Relay1SetPoint then Relay1 is set, and this bit is set.  If the Relay1Mode is set to type 3 and if an Error of type 1, 2, 3 or 4 is set then Relay1 is set, and this bit is set.	This bit is automatically cleared when alarm condition no longer exists.
2	Relay 2 Active	–identical to actions for relay 1	

### 11.6 Instrument Level 4 Errors

Detailed description of Modbus Register 13 & 14, Instrument Level 4 Errors  
 Instrument Level 4 Errors are warnings. The errors conveyed are for informational purposes and usually do not result in erroneous readings. The servicing of these errors can usually be put off until the next service interval.

No.	Hex	Type	Name	Description
13,14	0x0d	Long Int	Level4Error	Instrument warning, readings OK
			Spare	0-1
			LiqLvlSensErr	2 Liquid Level Sensor
			ReadingError	3 Reading error (Err Single A/D reading)
			ReagentOld	4 Reagent is old and needs to be replaced (REPL)
			TempError	5 Temp error
			Spare	6-14
			LockedOut	15 The Unit is Locked Out For Maint (No Modbus Writes Allowed)
			Spare	16-31

Following is a description of the bits, the causing condition, and steps to clear the error if possible:

BIT POSITION	ERROR DESCRIPTION	CAUSING EVENT	CLEARING ACTIONS
0 - 1	Spare		
2	Liquid Level Sensor	The Liquid Level Sensor (if installed) has triggered, indicating a need for checking the reagent levels	This bit is automatically cleared when the liquid level sensors detect the presence of reagents.
3	Reading Error	A single A/D reading was in error. Smoothing and error rejection routines in the area integration math routines compensate for single errors, however, if such errors are continuous, such an error indicates a more serious problem	This bit is automatically cleared during the next sample cycle.  If such errors are continuous, the error is escalated in severity.
4	Reagent is old	Reagent needs to be replaced	Replace reagent and cycle power
5	Temp error	An error occurred in the temperature circuit. Either the sensor is bad or the cold plate has risen above 27.5 degrees. The reagents last longer if cooled, so a temporary loss of temperature control is not problematic, however, if such errors are continuous, such an error indicates a more serious	This bit is automatically cleared during the next sample cycle.  If such errors are continuous, the error is escalated in severity.  If error continues, check to make sure thermistor is plugged in. Otherwise, check thermistor open or

BIT POSITION	ERROR DESCRIPTION	CAUSING EVENT	CLEARING ACTIONS
		problem.	damaged.
6-14	Spare		
15	Locked-Out	User Initiated Lock-out	Cleared when put back in Service
16-31	Spare		

## 11.7 Instrument Level 3 Errors

Detailed description of Modbus Register 15 & 16, Instrument Level 3 Errors

Instrument Level 3 Errors are low priority errors. The errors may result in erroneous readings and the current chlorine reading should be discarded. The error may be resolved during the next sample.

No.	Hex	Type	Name	Description
15,16	0x0f	Long Int	Level3Error	Instrument error, readings questionable
			CalError	0 Calibration error (ZCAL)
			LinError	1 Linearization error (ZCAL)
			AutoZeroFail	2 Failure to Autozero correctly, may be due to bubbles in cell, dirty cell, old reagents, or damage.
			Spare	3-8
			TempError	9 Temperature error, will contribute to decreased reagent lifetime
			Spare	10-31

Following is a description of the bits, the causing condition, and steps to clear the error if possible:

BIT POSITION	ERROR DESCRIPTION	CAUSING EVENT	CLEARING ACTIONS
0	Calibration Error	Calculated slope does not fit within error band of linearization previously run.  Possible causes: Linearization not performed or out-of-date, dirty cell, old reagents, reagents not pumping, calibration standard not fresh or mixed incorrectly.	Check that linearization current, cell is clean, reagents are fresh and pumping, calibration standards fresh and mixed correctly.  Rerun calibration.
1	Linearization Error	Calculated slope out of range or area counts between Hi-Med-Lo linearization samples appear to be out of order.	Re-Prime reagents, check cal standards, and re-run linearization.  Linearization is usually performed at the factory,

BIT POSITION	ERROR DESCRIPTION	CAUSING EVENT	CLEARING ACTIONS
		A second possible cause would be if the reagents were missing or ineffective during linearization.	however, instructions for field linearization are found in the manual. If problem persists then suspect reagent tubing or more serious instrument problem
2	AutoGain Error	System unable to complete Autogain	Clean Cell, Check for obstructions, check for lack of response on one of the channels
3-8	Spare		
9	Continued Temp error	An error occurred in the temperature circuit or the system is not cooling. The reagents last longer if cooled, so a temporary loss of temperature control is not problematic, however, if such errors are continuous, such an error indicates a more serious problem.	If error continues, check to make sure thermistor is plugged in. Otherwise, check thermistor open or damaged.  Suspect instrument failure.
10-31	Spare		

## 11.8 Instrument Level 2 Errors

Detailed description of Modbus Register 17 & 18, Instrument Level 2 Errors

Instrument Level 2 Errors are severe. These errors require immediate service.

No.	Hex	Type	Name	Description
17,18	0x11	Long Int	Level2Error	Instrument Failure, requires intervention
			PostError	0 POST error (POST)
			ContinuedDataError	1 Multiple Data Errors-results are questionable
			ReagentOld	2 Reagent older than ReagentMonthTimer
			Spare	3-31

Following is a description of the bits, the causing condition, and steps to clear the error if possible:

BIT POSITION	ERROR DESCRIPTION	CAUSING EVENT	CLEARING ACTIONS
0	POST (Power On Self Test)	The errors contained in this section are caused by a failure of the instrument during power-on-self-test. This is usually due to an error in hooking up the instrument, a connector missing internally, or due to a hardware failure	Check wiring (internal and external) and try again.  If the problem persists, suspect a hardware failure.
1	Continued Reading error	If single A/D reading is in error the math can handle the problem, however, in this case, the A/D is continually out-of-range.  In this case, there were too many erroneous a/d readings to get a stable reading so the sample must be discarded.  Gain setting may be set wrong. Photodetector may be defective. LED may be set too bright. LED may be off.	A series of bubbles could cause this problem. If this is the problem, the problem will reset at the beginning of the next sample.  Gain setting may be set wrong. Photodetector may be defective. LED may be set too bright. LED may be off.
2	Reagent Replacement Overdue	Reagent is very old and is likely causing erroneous results	Replace reagent and cycle power
3-31	Spare		

### 11.9 Instrument Level 1 Errors

Detailed description of Modbus Register 19 & 20, Instrument Level 1 Errors  
 Instrument Level 1 Errors require the instrument to be taken offline. The errors described in this section are not resettable nor are they serviceable in the field.

No.	Hex	Type	Name	Description
19,20	0x13	Long Int	Level1Error	Instrument failure, take offline
			Spare	0 spare
			A/D error	1 A/D Continued Failure
			FlashReadErr	2 Continued flash data read
			FlashWritErr	3 Continued flash data write
			AddError	4 Addressing error Firmware
			MathError	5 Math Error Firmware
			StackOvfl	6 S/W stack overflow
			Spare	7-31

Following is a description of the bits, the causing condition, and steps to clear the error if possible:

BIT POSITION	ERROR DESCRIPTION	CAUSING EVENT	CLEARING ACTIONS
0	Spare		
1	A/D Continued Failure	Hardware Failure	
2	flash data read error	Hardware Failure	
3	flash data write error	Hardware Failure	
4	Firmware General	Firmware Failure	
5	Math Error	Firmware Failure	
6	Stack Overflow	Firmware Failure	
7-31	Spare		

# Xylem |'zīləm|

- 1) The tissue in plants that brings water upward from the roots;
- 2) a leading global water technology company.

We're a global team unified in a common purpose: creating advanced technology solutions to the world's water challenges. Developing new technologies that will improve the way water is used, conserved, and re-used in the future is central to our work. Our products and services move, treat, analyze, monitor and return water to the environment, in public utility, industrial, residential and commercial building services settings. Xylem also provides a leading portfolio of smart metering, network technologies and advanced analytics solutions for water, electric and gas utilities. In more than 150 countries, we have strong, long-standing relationships with customers who know us for our powerful combination of leading product brands and applications expertise with a strong focus on developing comprehensive, sustainable solutions.

For more information on how Xylem can help you, go to [www.xylem.com](http://www.xylem.com)



Service and Returns:

Xylem Analytics Germany

Sales GmbH & Co. KG

WTW

Am Achalaich 11

82362 Weilheim

Germany

Tel.: +49 881 183-325

Fax: +49 881 183-414

E-Mail [service.wtw@xylem.com](mailto:service.wtw@xylem.com)

Internet: [www.xylemanalytics.com](http://www.xylemanalytics.com)

**xylem**  
Let's Solve Water

Xylem Analytics Germany GmbH

Am Achalaich 11

82362 Weilheim

Germany